

D101-20:FM7

FM 7-40

U. S. Deposit

MMH
Copy 3

FIELD MANUAL

SCOUT DOG TRAINING AND EMPLOYMENT

HEADQUARTERS, DEPARTMENT OF THE ARMY

MARCH 1973

**MOS ADDITIONAL SKILL IDENTIFIERS
(AR 611-201)**

The MOS additional skill identifier for an 11B infantryman employed as a scout dog handler is P6.

The MOS OOC, Dog Trainer, designates a primary skill as an instructor in military dog training. The MOS additional skill identifier for OOC in scout dog training is P6.

COMMENTS ON MANUAL

Users of this publication are encouraged to submit recommended changes or comments to improve the publication. Comments should be keyed to the specific page, paragraph, and line of the text in which the change is recommended. Reasons should be provided for each comment to insure understanding and complete evaluation. Comments should be prepared using DA Form 2028 (Recommended Changes to Publications) and forwarded direct to the Commandant, United States Army Infantry School, Fort Benning, Georgia 31905.

SCOUT DOG TRAINING AND EMPLOYMENT

	Paragraph	Page
CHAPTER 1. INTRODUCTION	1-8	3
2. SCOUT DOG TEAM TRAINING		
Section I. Screening Dogs for Training	9, 10	5
II. Principles of Training	11-13	5
III. Training Requirements	14-19	6
CHAPTER 3. THE FOOD-REWARD METHOD		
Section I. General	20	9
II. The Search Chain	28-32	14
CHAPTER 4. BASIC SCOUTING		
Section I. General	33-35	27
II. Suspicious Training	36-38	29
III. Training Considerations	39-47	29
IV. Integration of Tripwires, Mines, Boobytraps, and Caches	48-56	35
CHAPTER 5. INTERMEDIATE SCOUTING		
Section I. Training Considerations	57-60	43
II. Effects of Wind and Terrain	61, 62	44
III. Detection of Personnel and Equipment Underground, Above ground, and Underwater	63-66	50
IV. Night Training	67-69	53
CHAPTER 6. SPECIALIZED TRAINING		
Section I. General	70, 71	55
II. River Crossing	72, 73	55
III. Rappelling	74, 75	57
IV. Search of Built-Up Areas	76-81	66
CHAPTER 7. ADVANCED SCOUTING	82-86	69
8. EMPLOYMENT		
Section I. General	89, 90	71
II. Types of Employment	91-100	73
APPENDIX A. REFERENCES		81
B. PATROL BRIEFING DATA GUIDE		82
C. SENTRY DOG TRAINING		84
D. BASIC SCOUTING AREA LAYOUT		97
INDEX		98

CHAPTER 1

INTRODUCTION

1. Purpose

This manual is a guide for Army personnel charged with the training and employment of scout dog teams. When combined with other applicable manuals and programs of instruction, this manual forms the basis for conduct of a formal program for the training of scout dogs and handlers. Additionally, this manual provides guidance for commanders and staff officers in the capabilities, limitations, and tactical employment of scout dog elements in infantry operations.

2. Scope

This manual covers the general and specialized aspects of the training and employment of scout dogs and handlers.

Note: FM 20-20, Basic Care and Training of Military Dogs, is a prerequisite for use of this manual relative to dog training.

3. The Scout Dog Team

The scout dog team consists of one trained German Shepherd scout dog and one school-trained handler. Most of the information in this publication deals with the training and employment of this element. Scout dog teams can be grouped with administrative, technical, and command and control personnel to form scout dog platoons or sections of composite tactical dog platoons. A detailed discussion is contained in chapter 8.

4. Scout Dog Team Mission

The mission of the scout dog team is to support infantry combat operations by providing silent, early warning of foreign presence or devices outside the main body of supported troops.

5. Capabilities

The scout dog's superior senses of smell, hearing, and sight enable it to give silent indication of the presence of a variety of foreign presences. Combined with the handler's ability to interpret these indications and judge their significance, the

team can provide the commander with the following:

a. Silent, early detection of individuals or groups in the vicinity of a friendly patrol (ambushes, snipers).

b. Detection of infiltrators approaching a friendly position.

c. Assistance in the detection of tunnels, bunkers, or other means of hiding personnel and/or storing food, ammunition, or supplies.

d. Assistance in the detection of casualty-producing devices.

6. Limitations

Although the scout dog team is a tactical element, it is neither self-sustaining nor self-protecting. Since the handler must concentrate his efforts on interpreting his dog's reactions, and on controlling the dog during contact with the enemy, the team is normally provided with one or more bodyguards to protect the team until the handler can defend himself or withdraw from contact.

7. Evolution of the Concept

a. The scout dog, under various names, has supported combat operations for over 5,000 years. The requirement for a means of providing early warning of the enemy is essential to any army.

b. The modern evolution of the scout dog team as a tactical element began in World War II, when large numbers of scout dogs were employed successfully by the Allied and Axis powers in all theaters of operation. The United States deployed and utilized large numbers of scout dogs during World War II (15 platoons), the Korean Conflict (3 platoons), and the Vietnam Conflict (25 platoons).

c. Although the scout dog's most effective utilization in the past has been in unconventional or counter guerrilla warfare, the adaptability of the

concept (the use of modern behavioral training methods, and the development of electronic control measures) will insure the value of the scout dog team in any future conflict.

8. Responsibilities

a. Training. The US Army Infantry School

has responsibility for training instructors, leaders, handlers, and dogs in the scout dog program.

b. Command. Commanders are responsible for the proper employment, handling, care and continued training of scout dogs assigned or attached to their units.

CHAPTER 2

SCOUT DOG TEAM TRAINING

Section I. SCREENING DOGS FOR TRAINING

9. Procedure

The scout dog is the basic infantry tactical dog. As such, it must be more versatile and adaptable than other military working dogs. The term "screening" refers to the procedure used to classify dogs for the type of military service for which they seem best qualified. This classification is based on observation of the physical and psychological traits manifested by the dogs from the time they are tested upon arrival at reception and training centers, throughout their basic training period, and even after they have begun specialized training. It is imperative to continue observing the dogs throughout the training program. The potentialities of some dogs and inherent weaknesses of others may come to light unexpectedly. The dogs are initially observed by a classification board consisting of a commanding officer and selected instructors. On the basis

of physical and psychological traits manifested, the board may reject a dog before it is accepted, or at any time during training.

10. Selection for Type of Specialized Training

The classification board has the responsibility for deciding which dogs will be trained as *scout* dogs and which will be trained for other duty. The selection is based on consideration of the demonstrated qualities of an individual dog as measured against the requirements for the several types of duty. Scouting makes many demands on a dog's intelligence, temperament, and stamina. Dogs that qualify best in these traits may be selected for scout training. During the course of scout training, a dog may show that it is not, after all, suitable. It may then be transferred to another type of training.

Section II. PRINCIPLES OF TRAINING

11. General

Basic dog training is an end in itself. It serves simply, but necessarily, to develop in dogs the behavior that is essential to efficient and effective training for specific military functions. A dog that successfully completes basic training is disciplined and prepared to receive instruction in its particular military duties. Furthermore, its behavior during basic training, if properly observed, is an indication of the type of specialized training for which it is best suited.

12. Scout Training

a. Training the dog to scout begins immediately after obedience training. This training is subdivided into basic, intermediate, and advanced scouting. During the latter portion of training rappelling, village and/or built-up area search,

and river crossing are integrated into the training.

b. Basic scouting emphasizes teaching the handler how to read his dog's alerts, teaching the dog what to alert on, and developing team ability in scouting techniques such as quartering the field and suspicious training.

c. Boobytraps are introduced during intermediate training along with medium range patrolling. Emphasis is on tripwire explosives and mines.

d. In advanced scouting the handler is ready to employ what he has learned. Decoys are set out over a large area and the handler is subjected to all types of terrain and unusual conditions in order to find the decoy. A number of dog teams are taken out on patrol with one team scouting at a time. The handler should now be ready to

detect the enemy and his devices. He learns to scout over dry ground, hills, and swamps. Obstacles such as crossing a log, a stream, or a deep ravine should be mastered so that both the dog and handler gain confidence.

13. Statement of Principles

The effectiveness of specialized dog training depends on the regard shown for the following fundamental principles:

a. The General Attitude of the Handler. A handler must fully realize the importance of the work that he is doing. He must understand and appreciate the fact that dogs are used to conserve manpower, conserve life, and to further the work of the military service through the use of their innate abilities.

b. The Importance of the Handler-Dog Relationship. The dog and handler must work as a team. Therefore, no handler must be forced to train an animal that he deems unsuitable. For the same reason, if a dog appears unwilling to serve a certain handler, it may be necessary to assign it to another. On the other hand, once a team has been established, the relationship should be maintained. Only the handler should praise, feed, or otherwise handle his dog.

c. Association of Ideas Facilitates Learning. Where special equipment is used, the dog must learn to associate this equipment with its work.

d. Motivation. The dog should be motivated not only by food, or by praise and petting, but

also by the goal of accomplishing a mission. The dog can and should be trained to complete a task as an end in itself, not simply for the sake of reward by the handler. In all training, therefore, the dog must be permitted to finish every exercise successfully, no matter how many errors it makes. The dog must *always* succeed.

e. Terrain, Distractions. Training is conducted over varying terrain and in the face of gunfire and other distractions to develop the dog's responsibility for given tasks and to insure the accomplishment of its mission.

f. The Ability of the Dog is Developed by Training During Daylight. The effects of daylight training will carry over into actual service at night. Training is difficult to conduct in darkness because the handler cannot see well enough to observe the dog's errors and correct them. But the dog can carry over the effects of good daylight training into night performance. The dog and handler must be proficient in daylight training before any training at night is attempted.

g. Review of Previous Training Maintains and Raises the Level of Performance. Handlers must use their best judgment in determining how often previously learned exercises should be repeated.

h. Successful Training of Scout Dogs Depends on the Care Taken for Their Welfare. Unless the dogs are kept in good health, properly groomed, fed, and kenneled, the effectiveness of the training program will be diminished.

Section III. TRAINING REQUIREMENTS

14. General

Most types of military dog training require an unusually high instructor/student ratio. Except for obedience training, nearly all practical training must be conducted on an individual basis. The primary reason for this is the fact that the instructor/trainer will normally be training students with untrained dogs. Since the dog cannot understand verbal instruction, the instructor/trainer must "filter" his instruction to the dog through the medium of a student who is himself untrained. This unique aspect of military dog training demands an unusually high degree of expertise and patience on the part of the instructor/trainer. Other reasons include the types of terrain over which instruction is conducted, and the fact that each student team must be worked individually on uncontaminated training lanes.

It is therefore necessary that sufficient qualified personnel be available to permit the assignment of one instructor/trainer to three student/dog teams (in effect, one instructor to six "students"). To provide realism, insure troop and dog safety, and achieve the requisite technical proficiency, this ratio should be maintained as closely as possible.

15. Instructor/Trainer

Note: The instructor/trainer is so termed because he both instructs students and trains dogs, skills which are integrated yet distinct. For simplicity, he will hereafter be referred to as an instructor.

Responsibility for conducting scout dog team training should rest with qualified military dog trainers (instructors) (MOS OOC). Whenever possible they should have previous experience in

scout dog training. When a shortage of qualified trainers exists, experienced scout dog handlers may be used as assistant instructors. This is not, however, desirable since few handlers have the depth of experience necessary to cope with the many training and motivational problems that inevitably develop in training scout dog teams.

16. Handlers

A scout dog team consists of one scout dog and its handler. Handler/students must meet the requirements discussed in FM 20-20. The handler is responsible for the daily care and grooming of his dog and the maintenance of its kennel area. Since a strong bond of affection between dog and handler must be established and maintained, each handler should be assigned only one dog, and he should retain that animal until they graduate as a team or until one of them is eliminated from the training program.

17. Dogs

Sufficient dogs must be available so that there is one for every student to be trained. An additional number of dogs equal to at least 10 percent of each student class should be available. In any given group, a certain number of students and dogs will not be psychologically or motivationally compatible, thus, sufficient excess dogs must be available to allow for proper "mating" of handler and dog.

18. Equipment

Scout dog handlers require the following equipment in addition to their normal field gear:

- a. Choke chain collar.
- b. Leather collar.
- c. 5-foot, and 25-foot leashes.
- d. Feed pan.
- e. Kennel or "stake out" chain.
- f. Equipment holder.
- g. Intrenching tool.
- h. Harness.
- i. A pouch or bag for carrying food.
- j. Whistle.

The military construction worker's apron (fig 1) is ideal for carrying food, although ammunition pouches or other items which can be secured to the web belt are acceptable.

19. Terrain

All infantry tactical dog training requires large areas of terrain. Fifty student scout dog teams, for example, require a minimum of 10,000 acres of training area. A good rule of thumb is to multiply the number of teams by 100 acres, and then double or triple this figure to allow for rotation. There are three primary reasons for these large terrain requirements.

a. *Contamination.* After scout dog training has been conducted in a given area for approximately 1 week, the area becomes so contaminated by confusing human and animal scents that it



Figure 1. Military apron used to carry food for dog.

becomes difficult or impossible for the dogs to distinguish between these scents and those of the personnel they are expected to locate. For this reason, areas should be rotated weekly to allow the distracting scents to dissipate, the vegetation to recover, and to prevent the dogs from becoming too familiar with a given area.

b. Safety and Proximity. Since nearly all scout dog training is conducted in the off-leash mode, the teams in training must be dispersed to prevent the possibility of injury to personnel or dogs by dog fights. In addition, training lanes must be far enough apart so that a team working one lane is not distracted or interfered with by a team on another lane.

c. Diversification. The scout dog team must be trained to operate effectively over any type of terrain. For this reason, maximum use must be made of the terrain diversity in any military training area. Ideally, basic scouting should be conducted over relatively open, level terrain. As the complexity of training progresses, so must the complexity of the terrain. The final stages of advanced scouting should be conducted over the most difficult terrain available, making maximum use of hills, streams, woods and all-type natural and manmade obstacles. A final point is that, where feasible, training should be conducted in an area which resembles the area to which the teams are to be deployed (service unit).

CHAPTER 3

THE FOOD-REWARD METHOD

Section I. INTRODUCTION

20. General

There are two basic methods used in the training of military dogs, the praise-punishment method and the food-reward method. Both methods make use of the principle of reward for performance and punishment for nonperformance or misbehavior.

a. Praise-Punishment Method. This is the traditional method used by animal trainers. Simply stated, when the dog successfully performs some task it is rewarded by praise and petting. When it fails to perform, or misbehaves, it is punished by verbal disapproval and physical discomfort or mild pain. This method is most effectively used where highly disciplined dogs are required, and in training military dogs which must be highly aggressive.

b. Food-Reward Method. This method is relatively new to military dog training, although it has long been used by animal behaviorists. It is also referred to as behavioral conditioning, stimulus-response training, or operant conditioning. In this method, the animal is conditioned to associate the performance of a task or the presence of a particular object or odor with the appearance of food and praise. The dog learns that performing a task, such as locating an object or scent, will bring the food reward and praise. Here the food-reward method departs from the traditional method in that it advances the degree of subtlety. Failure to perform a given task, rather than bringing physical punishment, brings only the absence of food. This may seem overly simple, but since food is, after sex, the most important motivation to the dog, the method is extremely effective. This method is most effectively used in training military dogs which must perform a large variety of unrelated tasks, or where the task to be performed is quite complex or difficult. One important advantage of this method is that, out of a given group of untrained dogs, a larger percentage can be suc-

cessfully trained, to a higher overall degree of proficiency, in less time than by the praise-punishment method.

21. Food

Two types of food are necessary for successful use of the food-reward method:

a. Training Food. This is the food given the dogs as a reward for performing some task. For this purpose a commercially-prepared soft-moist dog food (FM 20-20) in the form of cubes or large pellets is used. The cubes must be easily handled and must not crumble when handled. Each handler will require 1 to 2 pounds of training food for his dog each training day.

b. Goal Food. Goal food is a key factor in the use of the food-reward method. This food is given after the last work session if the dog has performed well. For this purpose, use a commercially-prepared, meat-base canned dog food which is especially appetizing. At the completion of the last work session of the day, the dog is given the remainder (if any) of its prescribed daily ration of training food plus the canned food. If a dog has not performed well that day, *it receives no goal food!* (Goal food is not given on nonworking days.) The dogs quickly learn that they must perform well each day in order to earn their goal food. **REMBER: THE KEY TO USE OF THE FOOD-REWARD METHOD IS THAT THE DOG RECEIVES ONLY THE FOOD THAT IT EARNS! THE DOG IS NEVER GIVEN FREE FOOD.**

22. Preparation

Prior to introducing a dog to the food-reward method, it is first necessary to deprive the dog of food for 48 hours. This is normally done over a weekend. By doing this, the dog's hunger will increase its motivation to learn. During training, the dogs are also partially deprived on weekends

and other nonworking days. Depending on each dog's food requirements, appetite, and motivation, it may be given full ration (minus goal food) on Saturdays and half-ration on Sundays or half-ration on Saturdays and no ration on Sundays.

23. Veterinary Supervision

Close coordination with and supervision by the station veterinarian is necessary when using the food-reward method. No dog should undergo the preparatory food deprivation until the veterinarians has insured that the dog's state of health will allow it. Due to variations in motivation and appetite, some dogs will gain or lose weight during training. Close coordination with veterinary personnel will prevent excessive weight loss or gain. If a dog is unable to learn quickly enough to earn its minimum daily ration, it should be eliminated from training.

24. Training Pens

Although not essential, training pens facilitate the introduction of the food-reward method by

isolating each team while working and by reducing the amount of training area required. There should be one pen per five teams in training; when necessary, up to ten teams can work with one pen, but the number of trials per team will be reduced. Each pen (fig 2) should be constructed of any fence post material and 48-inch chicken wire. Dimensions should be 10 feet wide by 20 to 30 feet long. One end should have a simple gate in it. If pens are unavailable, conditioning must be performed with the dogs on leash. (See appendix D, example layout of basic scouting area.)

25. The Reinforcer Word—Good

The word "Good" is used throughout training as a reinforcer to inform the dog that it has performed an expected task properly and/or that food is about to appear. "Good" is called a reinforcer, not a command, since it is normally given in a low-to-moderate, pleased tone of voice rather than in a commanding tone. Food is the other reinforcer for training purposes. ("Good" and food are called positive reinforcers; punishment is a negative reinforcer.)

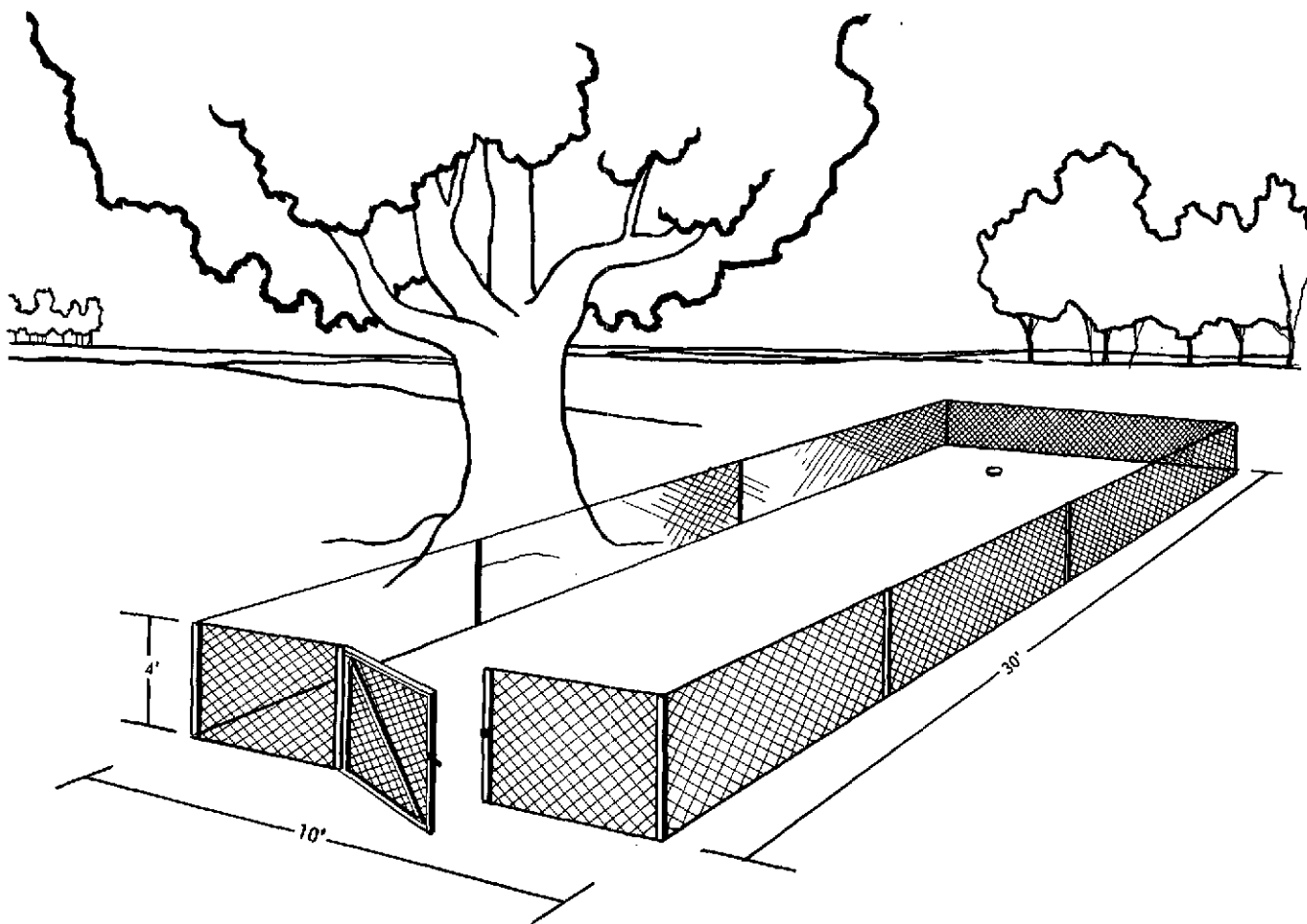

Figure 2. Training pen.

26. Conditioning of "Good"

Each handler should wear his apron filled with training food. The apron is worn at the waist, in front of or on the right side (fig 3). The handler will take his dog into the pen, close the gate, and remove his dog's leash. The dog is allowed to roam about the pen for a few minutes to accustom itself to its surroundings. The handler then begins the conditioning to "Good."

a. Step 1. Whenever the dog is near the handler, and especially if it is looking at him, the handler says "Good;" 1/2 second later he takes a cube of food from his apron and places it in his dog's mouth (fig 4).

Note: Timing is essential during this and all future stages of conditioning. The procedure must *always* be: "Good;" 1/2 second pause, appearance of food. The handler must not give the dog any cue or signal, such as reaching toward the apron or bending over before the word "Good" is said. This procedure is continued for several trials, until the dog starts watching its handler and waiting for food, or otherwise exhibits what is termed "begging behavior."

b. Step 2. The handler waits until his dog looks or moves away from him before saying "Good" followed 1/2 second later by food as before. When the handler is sure his dog is responding to "Good" and not other signals, such as various body movements, he can begin "shaping" his dog's responses. Conditioning of "Good" is considered complete when the handler can "shape" the dog to move away from him with the word "Good." Training time for the average dog is five or six trials, each lasting 10 to 15 minutes.

27. Exercise in Shaping Procedure

a. Step 1. To shape the dog's behavior into a certain response, such as moving away from the handler, he says "Good" whenever his dog looks away from him until the dog repeats "looking away" consistently.

b. Step 2. The handler waits until his dog makes a slight move away from him before saying "Good," and continues this until the dog repeats "starting to move away."

c. Step 3. The handler waits until his dog takes a step away, then several steps, or until the dog moves 4 or 5 feet each time, before saying "Good" and have the dog return for food.

d. Step 4. When the dog repeats "moving away," the handler may wait to say "Good" until the dog moves in a desired direction. The instructor must insure that the handler doesn't expect too much of his dog at one time. The

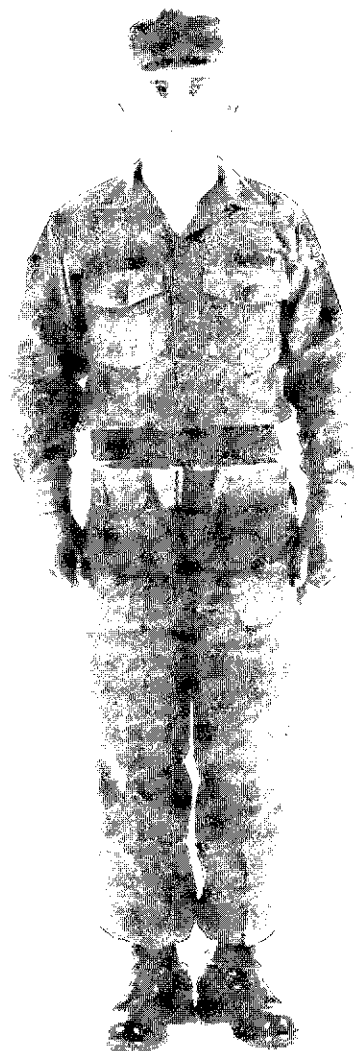

Figure 3. Handler wearing military apron.

handler will have to wait a long time for his dog to accidentally go to the right spot in the pen. He will have to wait again to get his dog to continuously go to that spot, and he must expect only slow results. During this phase of training some dogs will become quite confused, and many will constantly hesitate until they are sure they are performing the correct action. Many handlers will also become impatient or discouraged during this period, especially if they see other handlers' dogs progressing faster than their own. The instructors must constantly remind the handlers that each dog progresses at its own pace and encourage them to be patient. If a handler becomes disgusted or loses his temper, any benefit from that day's training may be lost.

e. Steps 5 and 6. One good technique for get-



Figure 4. Placing food in dog's mouth.

ting the dog to move to a certain spot in the pen is to "Divide" the pen into progressively smaller sections. The handler should stand in the center of the pen. He may then reinforce his dog only when it is in that half of the pen to his front (fig 5). Next, he may reinforce his dog only when it is in one quadrant (fig 6), and so forth until the dog continuously moves in only

one direction. The handler constantly withholds reinforcement until his dog gets a little closer to the desired spot, and expects a little more each time. Once the handler has his dog going to a particular spot, he must never reinforce his dog for doing less, such as going only halfway to the spot. Training time for the average dog is two or three 10 to 15 minute sessions.

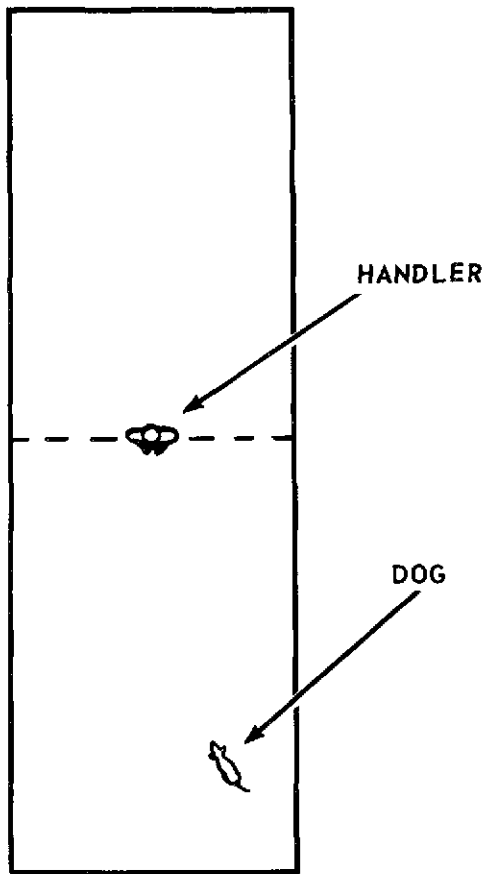

Figure 5. Dividing pen (training facility), dog in one half of pen.

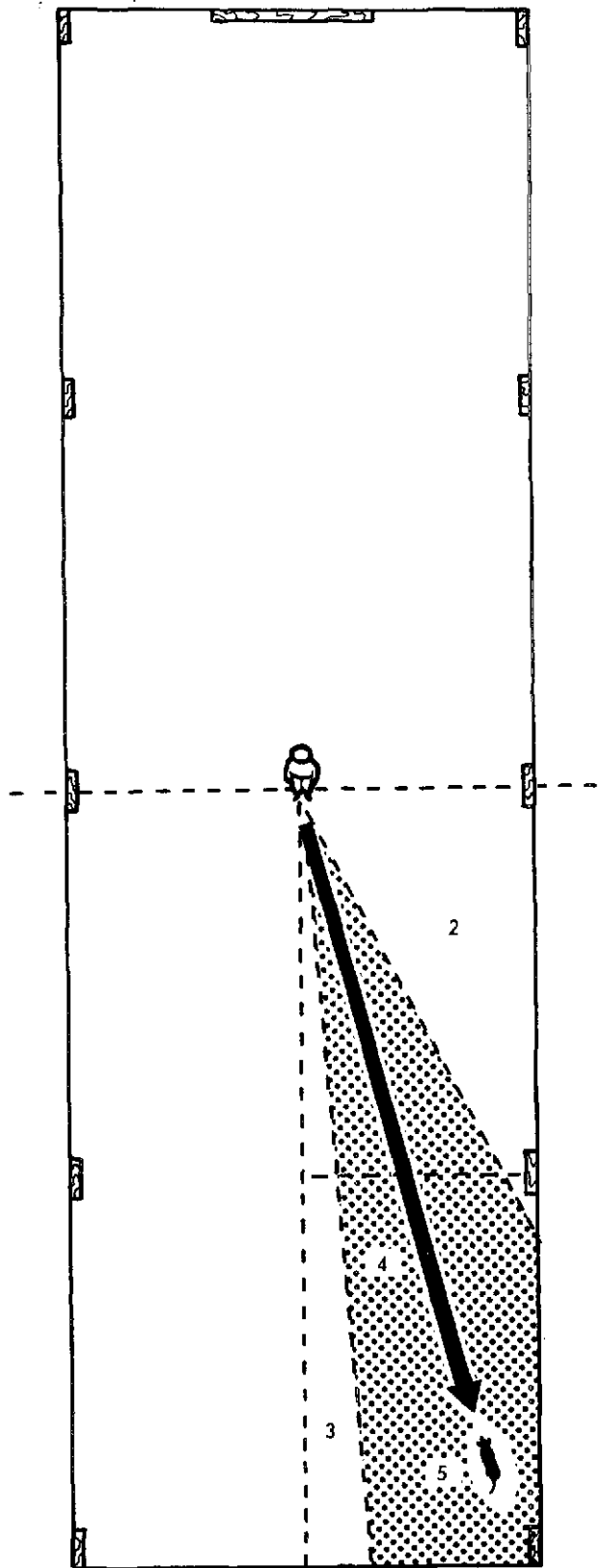

Figure 6. Dividing pen, quadrant.

Section II. THE SEARCH CHAIN

28. General

The search chain (fig 7) is a sequence of events whereby the procedure outlined in paragraphs 20 through 27 is used to shape the dog's behavior toward some practical task (e.g., obedience exercise, finding people, boobytraps, and the like). In the same manner as the dog's behavior was shaped to go to a particular spot in the pen, it can be shaped to perform almost any desirable action.

29. Basic Search Chain

The basic search chain can be diagrammed as an unvarying, continuous sequence of simple events as follows:

$$S_1 + R_1 \rightarrow Rf_1 \rightarrow S_2 + R_2 \rightarrow Rf_2 \rightarrow$$

As an example, the above sequence can be read as "The First Stimulus (S_1) (a feed pan) plus the First Response (R) (going to the feed pan) leads to the First Reinforcer (Rf) (Good + food) which leads to the opportunity to go to the feed pan again which leads to "Good" + food which leads to"

30. Pairing

The primary purpose of the search chain is to provide a basic stimulus (S_1) which can be associated or "paired," with practical actions to teach the dog, in smooth steps, its job of finding people and objects. Simply stated, the basic stimulus (S_1) is paired with a new stimulus (S_2) until the dog responds to both. S_1 is then faded out of the picture until the dog responds only to the new stimulus. As an illustrative example, S_2 will represent a strange person or object, and R_2 the dog's response, which may be looking suspiciously at an object or alerting. Incorporating these new factors into the basic search chain, the procedure will look like this:

$$S_1 + R_1 \rightarrow Rf_1 \rightarrow S_{1,2} + R_{1,2} \rightarrow Rf_2 \rightarrow S_{1,2} + R_2 \rightarrow Rf_3 \rightarrow S_2 + R_2 \rightarrow Rf_4$$

which can be read as "the presence of the feed pan + the dog going to the feed pan brings food; this leads to the presence near the feed pan of S_2 ; the dog going to the feed pan and

alerting on S_2 brings food; this leads to S_2 near the feed pan; the dog alerting on S_2 brings food; this leads to the presence of S_2 without the feed pan; the dog alerting on S_2 brings food." By using this "pairing" procedure, any number of new actions or objects can be introduced to the dog in a short period of time.

31. Basic Search Chain Procedure (10 Steps)

a. Step 1—Orientation on Feed Pan. Before taking the dog into the pen, place a pan with water and an empty pan at the far end of the pen, so the dog can drink when it wishes. One man, called the "dropper," with food in an apron, will stand behind the pan (initially this should be an assistant instructor; later another handler can do this). The handler takes his dog into the pen and stands 6 to 12 feet from the pan, facing the dropper (fig 8). The dropper will take one cube of food at a time, hold it at about waist height (fig 9), and drop it into the pan so that it makes an audible "plunk," or noise.

Note: The dropper should first practice this so that the cubes will not bounce out onto the ground. Any food which falls to the ground, at any time, must be picked up and discarded. Otherwise the dog will look for this "free food" rather than pay attention to its work.

As quickly as the dog eats a cube, another is dropped. After five to six trials, the dropper halts and waits *until the dog looks into the pan* (orients) before continuing. Timing is important. The food must be dropped as the dog's head is going down to the pan, NOT when it is coming up. This procedure, if properly followed, will soon cause the dog to look into the pan as soon as it has eaten the previous cube. Orientation is considered complete when the handler takes his dog to the pan and it immediately orients on the pan. Training time for the average dog is two 10- to 15-minute sessions.

b. Step 2—Recall Training. Begin this session with a quick review of step 1. The handler should begin by standing about 2 feet from the pan. The dropper will drop one cube of food. After the dog eats the food the handler recalls it by giving the command (Dog's name) COME. Some dogs will want to stay at the pan, and

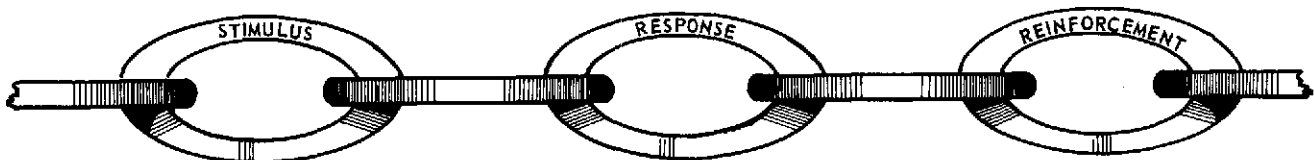

Figure 7. The search chain.



Figure 8. Orienting the dog on the feeding pan.

it may be necessary to take the dog by the collar with the left hand, gently lead it two or three steps away from the pan, and turn to the right to face the pan again. As the handler begins his turn to the right, the dropper drops a cube in the pan. At the same time the handler releases his dog which, hearing the noise (plunk), should go to the pan and eat. This process will normally be repeated three to four times before the dog starts returning without assistance. Each time the handler allows 3 to 4 seconds between his command and his movement to guide the dog. Initially, the sound should be heard as the dog's head is passing the handler's right leg (fig 10); at this point the handler insures that the dog continues around behind him and goes to the pan from his left (heel)

side. To do this he may have to start by grasping the dog's collar with his right hand until the dog's head is behind him, then bend and change hands, releasing the dog with his left hand as the dog passes the heel position (fig 11, 12, 13). When the handler has his dog returning satisfactorily without assistance, the dropper begins delaying until the dog moves a few inches farther around the handler, and continues delaying (with about five trials at each stage) until the food is hitting the pan just as the dog reaches the heel position. The dog is allowed to pass the heel position without being stopped. Recall training in the search chain is complete when the dog returns to its handler on command and is being reinforced as it passes the heel position on its way back to



Figure 9. Dropper's position.

the pan (fig 14). The dog should perform a minimum of 10 trials before going on to the next step in the search chain. Training time for the average dog is four to six 15-minute sessions.

c. Step 3—Stay at Heel Position. Begin by reviewing step 2. On about the fourth trial, the handler catches his dog's collar with his left hand as the dog is just to his left rear and holds it at the heel position (fig 15). The dropper delays dropping the cube *just until the instant the dog stops straining at the collar.* When the dog stops at the heel position with little or no pressure on its collar, the handler can stop holding his dog. Make sure, however, that the food is still dropped at the moment the dog stops at the heel position, until it has stopped on its own for eight to ten trials without

breaking the search chain. The dropper can then delay by fractions of a second over 10 to 15 trials until the dog is staying at heel for several seconds. Stay at the heel position is complete when the dog stays at heel for about 5 seconds before being reinforced, without breaking the search chain, and without the handler's assistance. Training: two to three 15-minute sessions.

d. Step 4—Moveout Command. (The command MOVEOUT, given in a low, firm voice, will be used to initiate nearly all future training exercises; it is also used to initiate operational patrols or exercises.) Review steps 1 to 3 as needed. After several trials of step 4, the handler gives the command MOVEOUT, accompanied by the moveout arm gesture. This gesture is accomplished by using the right hand and arm in a casting motion. With the fingers extended and joined, the right forearm is brought forward and up from the side until the fingers are pointing nearly straight up (fig 16). Continuing in a smooth motion, the forearm is brought smartly forward until the elbow is locked, with the arm parallel to the ground at shoulder height (fig 17). (REMEMBER: sloppy gestures produce sloppy performance by the dog.) The moveout command is given as soon as the dog sits; at the moment the moveout signal is complete, the dropper reinforces. This continues until the dog starts moving out on command, instead of waiting for reinforcement (10 to 15 trials). The dropper will then start delaying reinforcement until the dog is a few inches closer to the pan, and continues this procedure until he is reinforcing when the dog reaches the pan. This step is considered complete when the dog sits, waits for the moveout command, and goes to the pan before being reinforced (at least 10 trials). Training time for the average dog is two 15-minute sessions.

e. Step 5—Reorientation on the Pan. Review the previous step, then begin reinforcing when the dog looks at the pan, even though it may be several steps away (five to six trials). Some dogs will orient on the dropper at this stage and won't look in the pan. If the dog is losing interest in the chain of events, the dropper can silently place a cube in the pan as the dog is returning to its handler. This should cause it to look in the pan when it approaches, and the dropper can start reinforcing the pan orientation. This step is complete when the dog orients on the pan for 10 to 15 trials. Reorientation time averages two 15-minute sessions.

f. Step 6—Sit at the Pan. Review previous step. At about the fourth trial the handler gives

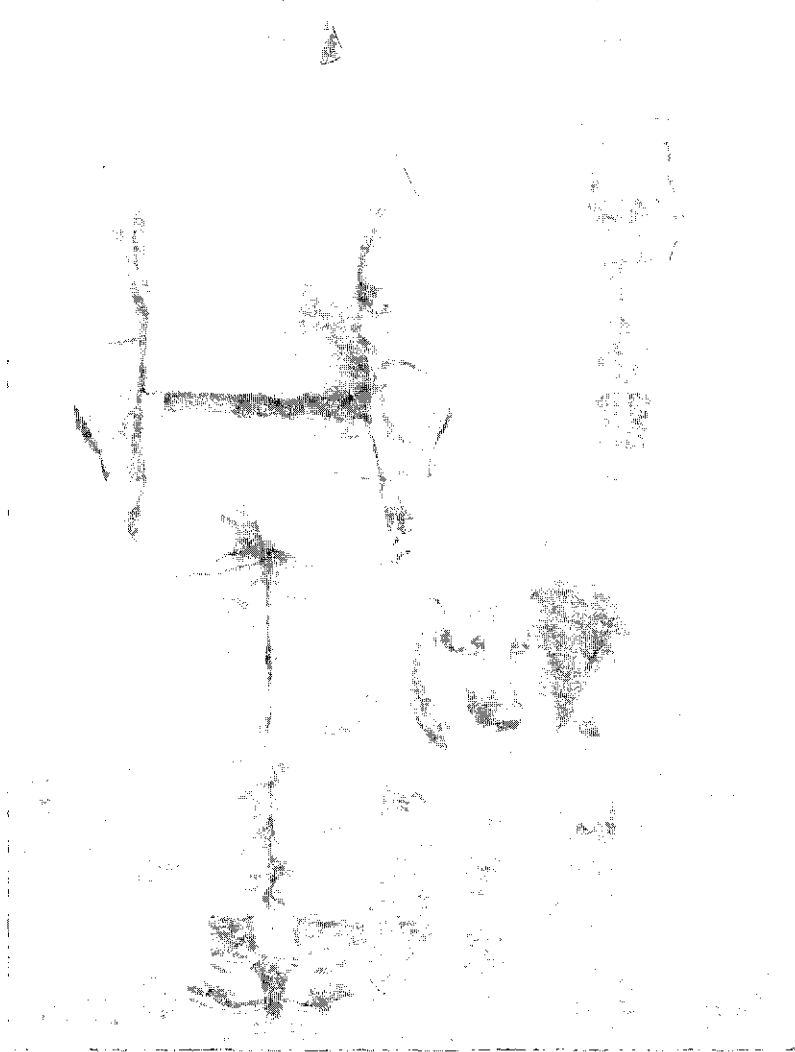

Figure 10. Food pellet dropped into feeding pan as dog passes handler's right leg.

the command SIT just as the dog is orienting on the pan and before its head comes up. The moment the dog sits it is reinforced, even though it may not be looking at the pan as it sits. If the handler giving the command interferes with the dog's position at the pan (the dog may want to face its handler), the dropper can give the command. After five to six trials the dog should orient on the pan and sit without command. If the dog fails to orient before sitting, the dropper may have to reinforce orientation for a few trials. Training time averages two to three 15-minute sessions.

g. Step 7—Reorientation After Sit. Review previous step and then wait to reinforce until the dog looks back at the pan. The dog may lose

interest after one or two trials and return to its handler to start again, but it should at least glance in the direction of the pan after sitting on the second or third trial. It can then be reoriented on the pan. Reorientation is considered complete after 15 to 20 successful trials. Training time: two to three 15-minute sessions.

Notes: 1. Notice that in the last several training steps, the dog was reoriented to the pan following the introduction to the new action. This procedure will continue into further stages of trainings.

2. When working the search chain, keep in mind that the dog must successfully complete *each* step in the chain in order to be reinforced. If it omits any step it is required to begin the trial again. Some dogs will try to take short cuts to get reinforced, such as remaining at the pan to get more food without working for it. The dog



Figure 11. Step 1—handler guiding dog to heel position (right hand).

soon learns that this doesn't work, and it returns to the search chain. Sometimes a dog will fail to stop at heel when it should, but again it is not reinforced; it is required to start again, and it learns that stopping at heel is the only action that will "turn on" reinforcement.

3. A common problem instructors must be alert for is that of handlers attempting to advance their dogs along the search chain too quickly. This will only confuse the dogs. Another pitfall is trying to teach a dog two tasks (e.g., orienting and sitting) at the same time. Again, most dogs will only become confused and quit working. This often causes the handler to believe his dog is stupid or lacks motivation.

h. Step 8—Reconditioning of Reinforcer "Good." In preparation for elimination of the dropper, the dogs must first be reconditioned to "Good" (i.e., "Good" will replace the noise at the feed pan indicating the appearance of

food). Review step 7; when the dog orients on the pan after sitting, the dropper reinforces with "Good," waits 1/2 second, then takes a cube of food, quickly places his hand, palm up, inside the pan and allows the dog to eat the cube. Since the dog has previously been conditioned to "Good," it should quickly learn that the voice sound "Good" has replaced the noise at the feed pan as the signal that produces food. Reconditioning should average two 10-minute sessions.

i. Step 9—Elimination of the Dropper. Review step 8. The handler will now take over the role of reinforcing his dog. When his dog orients on the pan after sitting, the handler reinforces with "Good," steps up to the pan and places his hand, palm up with food, into the pan, allow-



Figure 12. Step 2—handler continues guiding dog to heel position (both hands).

ing his dog to eat the cube. When starting this procedure the handler should stand about 2 feet to his dog's rear. He will alternate to his dog's left and right sides when reinforcing. This maintains the dog's position relative to the pan. The dropper will be standing in his usual position until it is determined that the dog has learned his reinforcement is coming from his handler. The dropper then takes one step back from the pan every two or three trials until he is out of the immediate training area. The handler and dog should be moving back to their starting point at the same time.

Note: After the dropper has been eliminated from the search chain, the handler can begin working on distance. He should take about one step back from the pan every three or four trials. **REMEMBER:** The dog is easily confused; handlers must not try to advance their dogs to

a new step until they are proficient at the previous step. This step is considered complete when the handler has gained a minimum distance of 15 feet from the pan and his dog is proficient without the dropper. Training time: four to five 15-minute sessions.

j. Step 10—Distance Training. Review step 9. Every three to four trials the handler takes one or two steps back from the pan. This procedure can be continued until the handler is at any desired distance from the pan; it should be carried to a minimum of 25 meters and can be continued out to 100 meters or more. Training time: four to five 15-minute sessions. This completes the search chain with the feed pan.

k. Goal Food. As described in paragraph 21b, goal food is that portion of a dog's prescribed ration not eaten during training *plus* one can



Figure 13. Step 3—handler completes guiding dog around (left hand).

of tasty dog food. Goal food should be given on the last trial of the day, since it is important to associate goal food with the dog's work. During the last session of the day, if the handler and instructor agree that a dog has performed well enough to earn its goal food, the goal food will be placed near the pan before the last trial is complete. At the completion of the last trial, instead of saying "Good" the handler says "Chow" in an excited, happy tone of voice. He moves quickly to the pan, maintaining his excited manner. It is important that the dog realizes that this procedure is significant and that the dog has caused it to happen by pleasing its handler. As soon as he reaches the pan, the handler prepares the goal food. He may talk happily to his dog or repeat "Chow" several

times while doing this. After receiving goal food, the dog does no further work that day, but the handler should play with his dog and groom it. For dogs that require more association of food with their work, it may be desirable to give a small portion of the daily ration on the last trial of each session. If so, it should be given in the same manner as regular goal food. The handler will need to know how many sessions his dog will work that day and regulate its food accordingly. The end-of-the-day goal food must be the largest portion. It is desirable, but not always practical, to give goal food at different times each day, so the dogs will not learn to anticipate it. Once a dog has learned that "Chow" will be followed by goal food, its handler can gradually increase the interval be-



Figure 14. Food pellet dropped in pan; noise to attract dog's attention.

tween "Chow" and receipt of goal food a few feet each day. This will be useful when working long lanes, as the dogs will run to their pans on "Chow" and wait for their goal food.

l. Timeout. A dog is "timed out" when it will not work, when it misbehaves or malperforms, whether through ignorance or deliberately. A common reason is lack of motivation for food. Instructors must insure that the handlers don't cause timeouts by expecting too much of their dogs or trying to advance them too quickly. This only confuses the dog; if it is confused or timed out too many times in succession, it may refuse to work at all. If a handler's dog is confused, he should reestablish its confidence by backing off to an earlier step of training that the dog can perform successfully. Once he has decided to

time his dog out, the handler must be sure that he gives the signal *at the moment his dog is doing something wrong*. A low, stern NO is a good signal for this purpose. After giving the signal, the handler immediately puts his dog on-leash, keeps it at close heel (fig 18), and takes it to an area away from other dogs and from its usual stakeout. After locating a suitable tree or post, the handler will tie his dog so that it cannot run around or lay down.

Warning: This is done only when directed by an instructor and under his supervision! (fig 19 and 20).

The dog is left alone, but the handler stays where he can watch to insure his dog doesn't choke or hurt itself. The instructor will determine if the dog should be timed out for a short period



Figure 15. Handler moves dog; left hand on collar.

and worked again, or timed out until the next day. In hot weather the dog will be staked in the shade with water. Most timeouts should not exceed 15 to 20 minutes.

32. Concurrent Training

Concurrent training is performed outside the pen without the search chain. It should include conditioning of "Good," MOVEOUT, COME, HEEL, SIT, DOWN and STAY.

a. Start on the 5-foot leash while conditioning "Good," then advance to the 25-foot leash and to off leash as the dog becomes proficient at the movements. Condition the dog to "Good" in the same manner as outlined in paragraph 26. The difference being that the dog is on-leash

instead of in the pen. Conditioning of "Good" outside of pen should progress at the same rate as inside. When the dog is conditioned to "Good," the handler can start shaping his dog to move away from him as outlined under paragraph 27. He should advance to the 25-foot leash at this time and shape the dog to a minimum distance of 15 feet before starting recall training.

b. Up to this point the dog has automatically returned to the handler when the word "Good" has been given. In effect, "Good" has been a form of recalling the dog. Now, the dog is to return on the command COME. It will be necessary to pair the old signal "Good" with the new signal COME. COME is given first, followed immediately by the old signal "Good." When the handler sees the dog starting to return on COME,



Figure 16. Step 1—moveout gesture, starting position.

he can start delaying the word "Good." As his dog starts to *turn* and come back to the handler when COME is given, the turn movement is reinforced with "Good." The dog completes the turn before hearing "Good;" the handler then waits until his dog takes a step toward him before saying "Good," then two steps and so on until the dog has been shaped to return to the handler's right side on COME before being reinforced with "Good."

c. When the dog is performing well on COME, the handler starts taking his dog by the collar with his right hand and gently pulling it around to his rear, catching the collar with his left hand and bringing the dog to the heel position. At the moment the dog reaches the heel position, its handler reinforces with "Good" and 1/2 sec-



Figure 17. Step 2—moveout gesture, completed.

ond later delivers a piece of food. After three or four trials the handler can start giving his dog HEEL when he reaches for its collar to guide it around and into the heel position. The handler gives less and less help to his dog as training progresses, until the dog is coming around him and stopping at the heel position on the commands of COME and then HEEL.

d. When the dog stops at the heel position, the handler puts his left hand at the base of the dog's tail and applied mild pressure until the dog sits. At the moment the dog sits it is reinforced with "Good" and then given food in the usual manner. When the dog starts sitting as the handler touches it at the base of the tail (croup), the handler can then start giving the verbal SIT command an instant before touch-



Figure 18. Dog at close heel.

ing the dog, until the dog is sitting on the verbal command for reinforcement and the touch has been eliminated.

e. When the dog is sitting on command, the handler takes the leash in his left hand, close to the dog's neck, gently pulling down until the dog goes down; the instant the dog is down the handler reinforces as usual. Continue with less pull on the leash each trial until the dog goes down on command without assistance.

f. The handler starts with the dog sitting at the heel position, gives the verbal command STAY and, holding the dog back with his left hand, takes a half step forward and then reinforces. This continues until the dog ceases trying to move with its handler and he can stop restraining his dog. He can then take two steps after giving STAY before reinforcing. Continue this procedure until the handler can move away from his dog to the desired distance. When the dog has learned all of these commands, the handler can then start giving them without a set pattern, such as giving the dog DOWN after moving to the end of the leash, or STAY when the dog is coming back on recall; each command given in this way should be reinforced because it is no longer a chain leading up to reinforcement as far as the dog is concerned. After the dog has learned to perform all of the commands, the handler can give a series of commands before reinforcing. If he wants a new signal or command to take over, or have the same effect as an old signal (i.e., he has already taught the dog to go down on the verbal command and he wants it to go down on the hand gesture), the handler gives the new command (hand gesture) an instant before giving the old command DOWN. The dog will associate this new signal with the old one and start working on it. The difference in the search chain is that the handler wants the dog to perform a series of events, one after the other, by giving the dog a minimum number of commands; in concurrent training he wants to gain control of his dog in all possible situations.



Figure 19. Dog staked for timeout—standing.



Figure 20. Dog staked for timeout—sitting.

CHAPTER 4

BASIC SCOUTING

Section I. GENERAL

33. Scope

a. During basic scouting, the handler learns:

- (1) How his dog alerts on different targets.
- (2) How to *read* (interpret) on dog's alerts.
- (3) How to work his dog on short (50- to 300-meter) patrols.
- (4) How to judge wind, weather, and terrain factors.

b. The scout dog learns:

- (1) That it must be suspicious of and find hidden human decoys.
- (2) That it must recognize and alert on tripwires, mines, boobytraps, and caches.

34. The Changeover

a. *The Leather Harness.* The use of the leather, or working harness is an important part of the dog's training. Most types of military dogs learn in their training to associate wearing of the choke chain or leather collar with obedience training, play, or rest, and associate the leather harness with work. The leather harness also removes the restriction around the dog's neck, gives it more freedom of action, and gives the handler greater control over his dog during adverse conditions such as difficult terrain or con-

tact with the enemy. It is therefore required that the collar be replaced with the leather harness prior to any scouting exercise. This procedure is called the *changeover*.

b. *Procedure.* The handler faces his dog into the wind and straddles it from the rear to effect the changeover (fig 21). He will run the leash down his dog's back, place the harness over the dog's head, and buckle it snugly (he keeps the loop over his wrist during this procedure). The handler will then unsnap the leash and attach it to the D-ring on the harness, holding onto his dog by placing two fingers under the harness. He then removes the collar and places it on his web belt, in his pocket, or an empty pouch of his apron.

35. Noise Discipline

From the beginning of basic scouting, the scout dog is always reprimanded if it barks or whines for any reason while working (except for suspicious and chase training). The scout dog may bark or whine only in the kennels or during play, stakeout, or travel periods. The handler can correct his dog by commanding NO. This failing, he may gently hold his dog's mouth shut. When necessary, he will strike his dog in the windpipe with his hand or grasp it by the throat and apply pressure until the dog stops trying to make noise (fig 22).

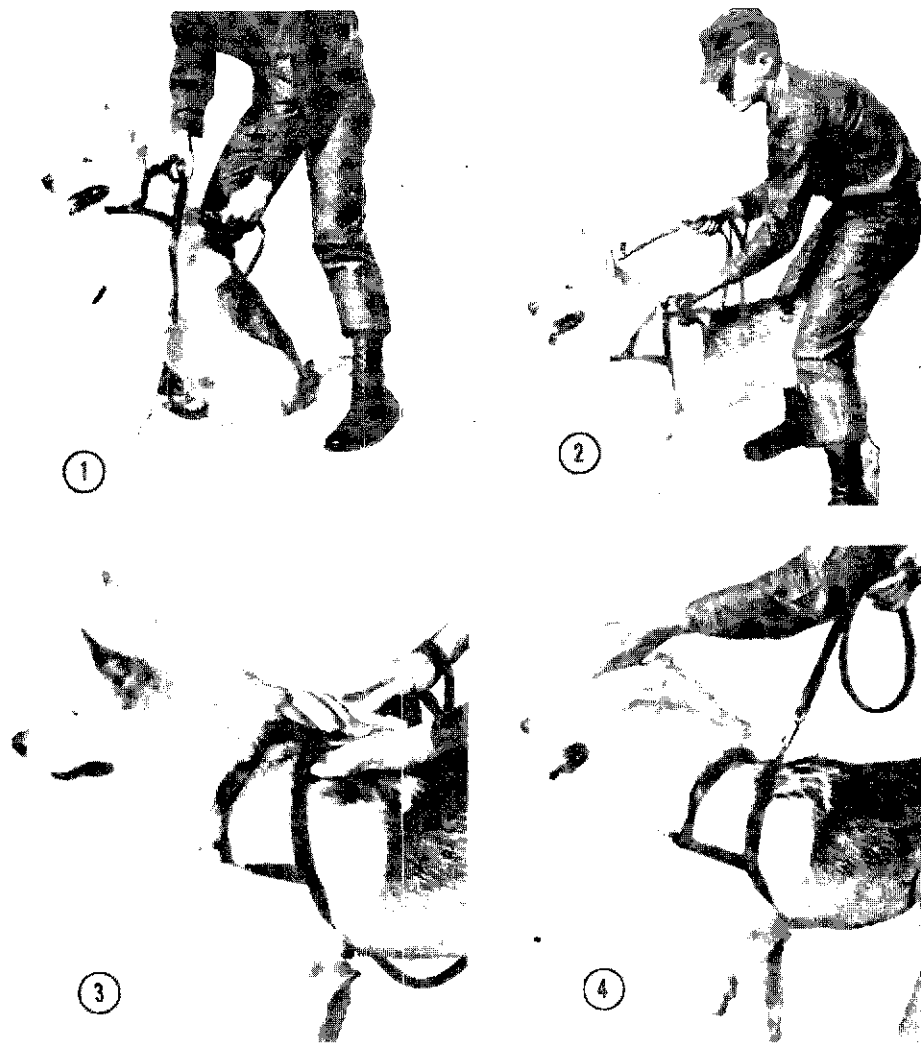

Figure 21. Changeover.



Figure 22. Silencing dog.

Section II. SUSPICIOUS TRAINING

36. Introduction

Suspicious training is conducted the first day of basic scouting so the handler can see exactly how his dog alerts on sound, sight, and scent. In suspicious training, the instructor places a decoy downwind, out of the scent and sight of the dog. He places the handler at a designated point, having the handler kneel by his dog. The instructor then has the decoy make a noise, such as clicking the safety of his rifle, so the handler can see how his dog alerts on sound. The decoy will then move in a crouched and suspicious manner so that the handler can see how the dog alerts on sight. The decoy then moves to a position upwind of the dog so that the handler can see how his dog alerts on scent. This should be repeated until the instructor is sure that the handler can recognize the dog's three types of alerts. Handlers should be given an understanding of the various techniques used to train a dog to detect and give early *silent* warning of enemy presence as well as how to read and interpret these alerts properly. Despite the scout dog's innate senses it is not instinct, but repeated training that develops the dog's desire to detect a hostile force and to do this *silently* under the control of the handler. It is also training that teaches the handler how to *read* his dog's behavior accurately; one must complement the other if a well-trained team is to result.

37. Types of Alerts

a. Natural Alert. The natural alert is normally used when alerting on personnel. Each dog will alert in its own individual manner. Some dogs will give a very pronounced alert, e.g., hackles raised, growling, tail erect, ears forward, or even standing on the hind legs. Other dogs may give no more than a slight head or ear movement. It is, therefore, necessary for each handler to observe his dog's behavior carefully when work-

ing so that he can determine when his dog alerts and judge the type of alert.

b. Conditioned (Sit) Alert. Scout dogs are conditioned to give the sit alert on objects: tripwires, pits, and boobytraps. This alert is unmistakable, and pinpoints the location of whatever the dog has found. Furthermore, it provides the handler with a clear distinction between personnel and object alerts. This is an important consideration when the handler must advise the commander on his dog's alert.

38. The Decoy

Decoys are personnel used to simulate the enemy. They play a vital role in the training of scout dogs. A poor decoy can retard or ruin a scout dog's progress.

a. Decoys should ideally be totally unfamiliar personnel. At least they should be from different training squads or groups, so that the dogs don't become familiar with them and lose interest.

b. Dogs associate certain happenings with certain localities, sounds, or people. During early basic scouting, decoys should *not* always conceal themselves behind only trees, rocks, or bushes. If, on the first several scouting runs, a dog finds its decoy behind the same object it will associate such objects with finding decoys. This will, consequently, cause the dog to rely on its eyesight, which is inferior compared to its senses of smell and hearing. This rule also applies to training areas. They should be rotated frequently so the dogs don't associate only certain areas with decoys.

c. Since a decoy may sometimes have to remain in position for several hours, he must not make himself so comfortable that he might tend to fall asleep. This problem is especially evident in very hot or very cold weather. This caution is particularly important if a decoy must perform some action when a dog team approaches.

Section III. TRAINING CONSIDERATIONS

39. Commands

There are three basic commands used when scouting: MOVEOUT, OUT, and NO.

a. The command MOVEOUT is used to start a scout dog searching. This command should be repeated only as often as necessary to keep the dog working. The command MOVEOUT should

be given in a low, suspicious tone of voice to arouse the dog. It should not be given so loud that it distracts the dog from its mission.

b. The second command introduced during scouting is the command OUT. This command signifies to the dog that it is to break off and either continue the search for another decoy or

the problem is over. The command OUT is not a correction. If the dog fails to react to the command then the handler precedes the command with NO.

40. Chase

During suspicious training, some dogs may show little interest in the decoys. Others may appear frightened or shy at first. Dogs that lack aggressiveness must have their confidence and interest increased if they are to be scout dogs. This can usually be accomplished by using the chase procedure. A handler can work his dog, on leash, to within 15 feet of a decoy. The decoy will rise from hiding in a slow, threatening manner. When he has the dog's attention, he will break and run straight away from the dog. The dog's chase instinct should take over at this time; the handler will encourage the dog by running with it, giving it verbal encouragements such as "Watch Him, Boy," or "Get Him." **THE DOG IS NEVER ALLOWED TO CATCH THE DECOY AS THIS MAY DIMINISH THE DECOY'S DESIRE TO BE CHASED.** The dog is allowed to pursue for 15 to 30 meters; by pre-arrangement the decoy will break to one side and the handler will give his dog OUT and break in the opposite direction. He will then praise his dog. During the chase the decoy does not shout or wave his arms as this may cause a dog to become noisy and aggressive, even though chase is the *one time* when the dog is allowed to bark.

41. Using the Wind

a. The wind is the most important consideration in the proper employment of a scout dog. In addition to the various scents carried to the dog by the wind, there are also sounds. Therefore, it is essential that a scout dog handler be wind conscious, because the wind direction dictates what route he should follow with his dog in order that the dog may pick up the scent of the decoy.

b. There are several methods by which the handler may check wind direction while running a problem. A reliable method is to watch the dog, as it will point its nose into the wind to sample and test the air currents. This is instinctive with dogs. The handler may remove his hat to allow his brow to come into contact with the wind. There will be a drying effect on the side exposed to the wind. By paying close attention he can also feel the wind blowing on exposed portions of his face and hands.

c. There are many ways of checking the wind, but there are also ways which should not be used for security reasons or because they might distract the dog from its mission. One method that is *not* recommended is pulling hair from the dog's back. This could be painful, if the handler is not careful, and physical contact with the dog can be a distracting influence. Kicking the ground and stooping over to pick up grass or dust is also distracting to the dog. There is also the risk that you might alert the enemy by the noise. Lighting a cigarette is dangerous, especially at night. So there are two points to remember when seeking a method of checking wind direction: Does it violate security? Will it distract the dog?

d. There are several points that should be taken into consideration when working the wind. If the sector to be cleared of decoys is rather narrow, usually no wider than 50 meters, then the handler ordinarily works his way straight into the wind allowing his dog to roam back and forth in front of him. On the other hand, if the area is quite broad, the former method is not advisable because the dog may miss a scent cone to its right or left; therefore, under such circumstances, the handler should check the area, starting at the downwind side and working diagonally from right to left, then left to right, or vice versa.

e. The wind is a variable factor, one that can play tricks on the handler and the dog if they are not careful. It is subject to change without notice, and many dogs will lose the scent only to regain it later when the wind switches back. There are also those dogs which will catch the scent of a decoy, forget about the wind, and start charging ahead blindly in the direction they alerted. This must be avoided, for if the wind should suddenly change the dog will soon run out of the scent cone and subsequently end up bewildered. It is always best to stop the dog momentarily after it alerts to confirm that it has alerted and to see if the wind might change. This stop-and-go method is also advisable periodically throughout the entire duration of the problem, for the same reason. It is particularly vital on any sudden wind change, so the handler can determine if a new pattern of approach is required if the wind fails to switch back. In short, do not rely on the wind always blowing from the same direction—it may be fatal if an enemy ambush is nearby.

f. If the handler observes his dog carefully he will notice that his dog often alerts and instead

of going straight-in the dog will angle off to its right or left. The dog does this because more than likely it has hit the edge of the scent cone and is working its way *toward the center where the scent is stronger*. He should pay strict attention to his dog's behavior at this moment. He should be able to determine by its actions whether the dog is working the scent cone or has lost interest (fig 23).

g. An important point for the handler to remember is not to permit the dog to lead him all over the area. Many dogs will do this if the handler doesn't watch them. They haven't alerted, they're just wandering. Therefore, the handler sticks to the route he is to follow, guiding his dog as necessary.

42. Speed

a. Many scout dogs develop a tendency to work too fast. This is usually due either to their over anxiety to find and give chase to the decoy or excess energy. A scout dog which works too fast is apt to miss alerts by running out of the scent cone. It will tire quickly and create undue noise. At night it could make enough noise to alert an enemy a half-mile away. Result: An ambushed patrol.

b. The handler must concentrate on slowing his dog down after the first few training problems. He must however, temper his corrections with judgment: They must not be so harsh that the dog is discouraged from working. Some recommended corrective measures are:

(1) Work the dog a few times without decoys, so it will learn not to expect decoys on every problem.

(2) Recall the dog periodically, make it sit until it settles down before continuing (fig 24).

(3) Let the dog trail the 25-foot leash. It will soon tire of the leash snagging or being stepped on by the handler.

(4) Tie a 10-pound weight to the leash and let the dog drag it. It will soon tire of this.

43. Silence

a. Silence is part of a good scout dog. A dog that barks or whines on patrol is a serious and costly liability. Not only will it alert the enemy to the patrol's approach or presence, it may also set the patrol up for an ambush.

b. Everytime a dog barks or whines, regardless of where it is, it must be silenced immedi-

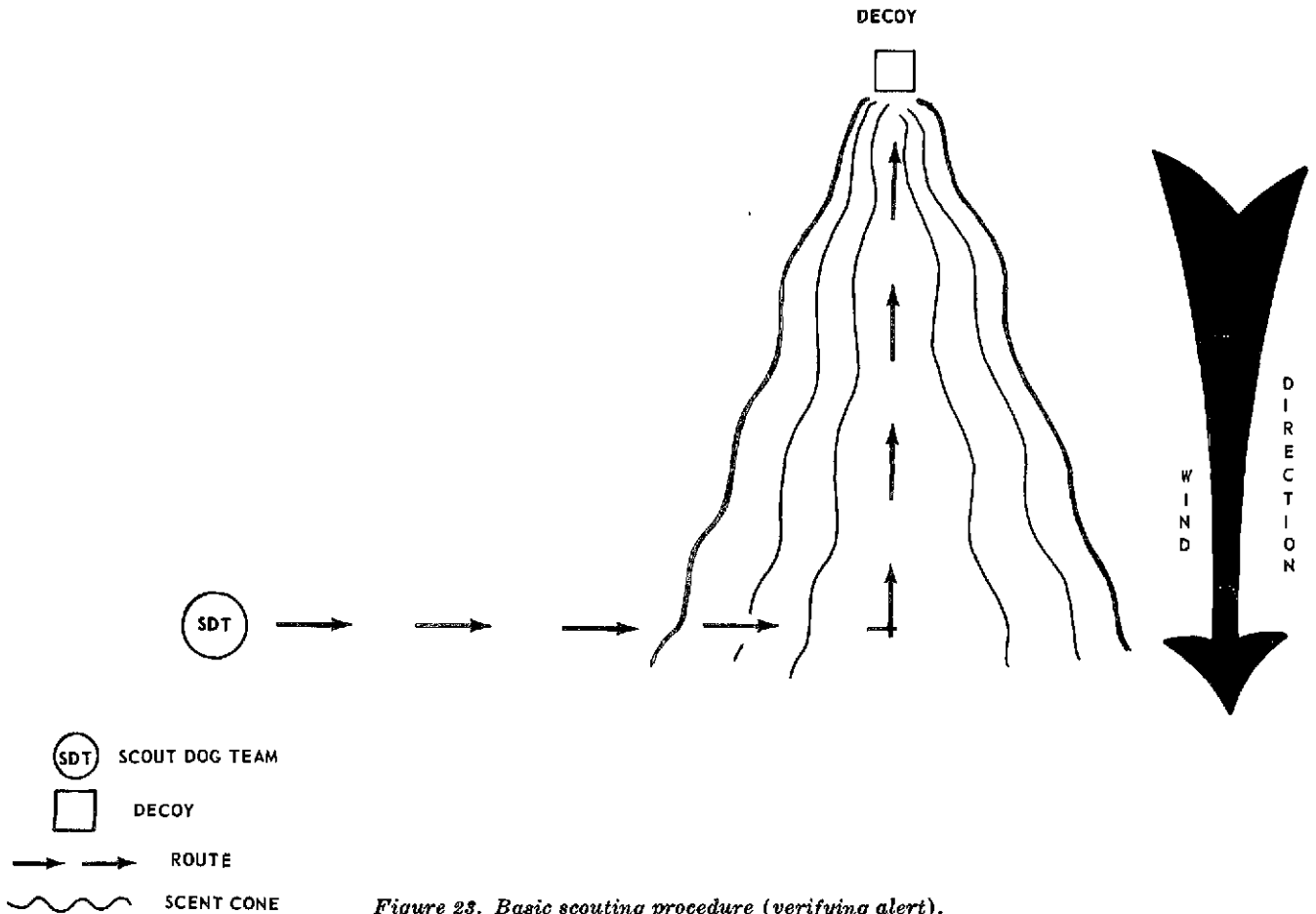

Figure 23. Basic scouting procedure (verifying alert).



Figure 24. Scout dog on patrol.

ately. The handler can do his by clamping his dog's mouth shut and commanding NO, or by choking off the dog's air supply momentarily until it is quiet.

c. Keeping scout dogs quiet is a *24-hour-a-day job* in a scout dog unit. If the dog's handler is not present to make the correction another handler or the charge-of-quarters should assume the responsibility. This they can do by commanding NO, or throwing a small object *near* the dog. The point is that a scout dog must be quiet. There is no other alternative.

44. Placing Decoys

a. Never walk across the area to be scouted. This will leave fresh tracks for the dog to follow if it is so inclined. In going to his position, the decoy should make a big sweep around the area to be worked, coming in from the rear (fig 25).

b. Never allow handlers or dogs to see where the decoy is being placed. This will cause the handler to lead his dog into the decoy instead of permitting the dog to find him using its senses of smell and hearing. On the other hand, if the dog sees where the decoy is hiding it will rely on its eyesight to find him. In such instances it is a waste of training time to even start a problem.

c. Once the decoy is in place he should remain silent and out of sight. He must refrain from smoking. Mistakes on the part of the decoy can cause a dog to become a sight-hunter.

45. Breaking a Scout Dog of Tracking

a. It is instinctive with dogs to track, but for a scout dog it is undesirable. The dog must learn to rely exclusively on airborne scent in order to be totally effective. A dog that tracks could lead a patrol into an ambush. Tracking is not a difficult habit to break, nor does it require an undue amount of effort and patience on the part of the handler, but it must be constant. All it requires is skill, repetition, and ample opportunity for the dog to pick up an airborne scent. For the latter reason the handler should try to avoid all situations which might encourage the dog to track.

b. There are two means by which a dog can be discouraged from ground trailing while on patrol: the handler can jerk its head up with the leash whenever the dog puts its nose to the ground, at the same instant commanding NO, followed by the command SEARCH. The most effective means is to eliminate the cause for tracking.

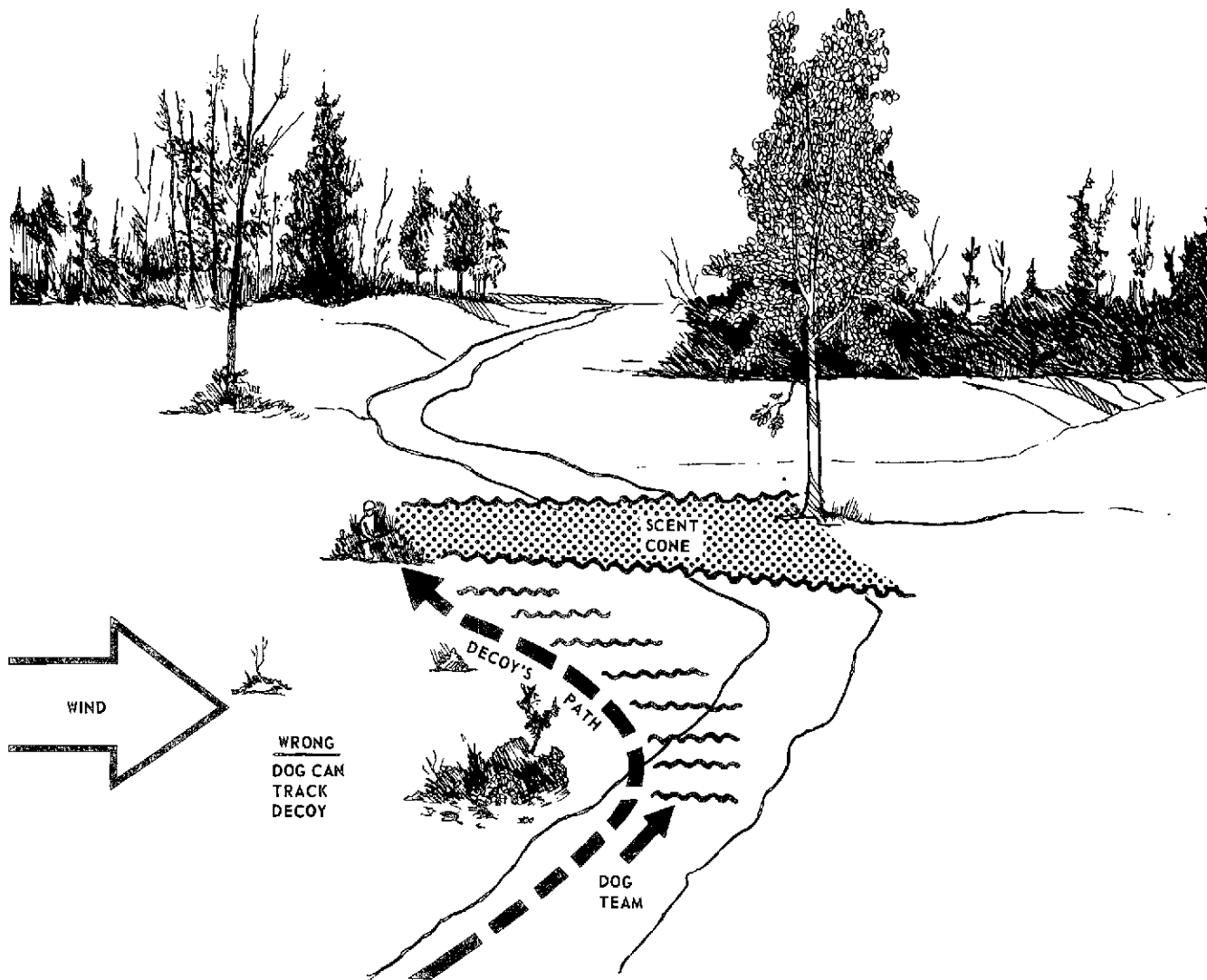

Figure 25. Placement of decoys.

46. Actions Taken by Handler When Going in on Decoy

a. In an actual combat situation the handler would never rush in on an enemy position. This is not the scout dog team's mission. The team is only a detection and warning device for the patrol. Therefore, in the latter stages of training, the handler will be taught what to do when his dog gives a definite alert and what actions to take in relaying information to the patrol leader.

b. It must be remembered that allowing a dog to go in on the decoy during training is done only to stimulate and maintain its interest, and to confirm that it knows where the decoy is located.

47. Sound and Smell Alerts

Sound and smell alerts are essential in the training of scout dogs and should be a familiar portion of the daily training. Best results may be obtained during night training, while conducting outpost and ambush patrols.

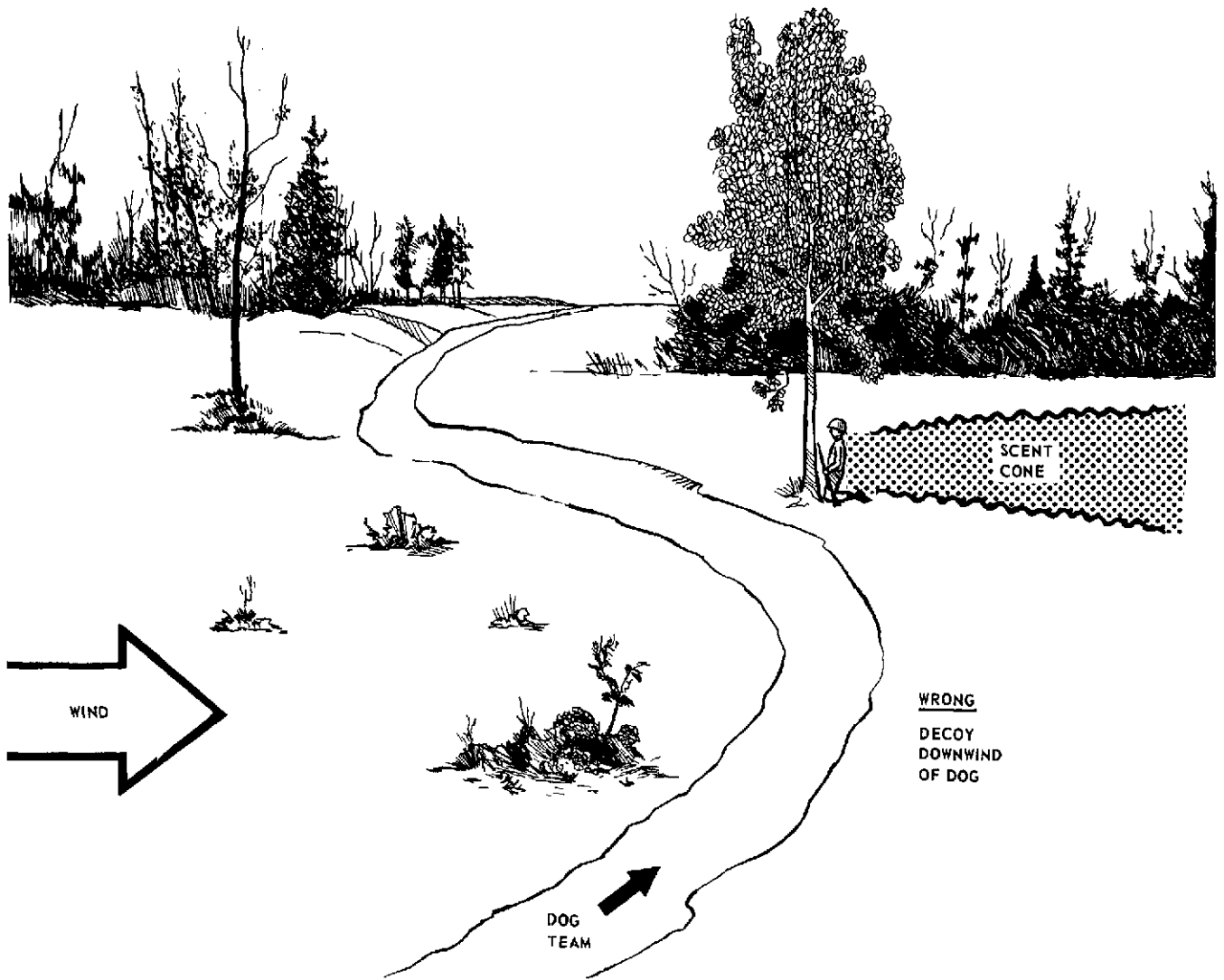

Figure 25—Continued.

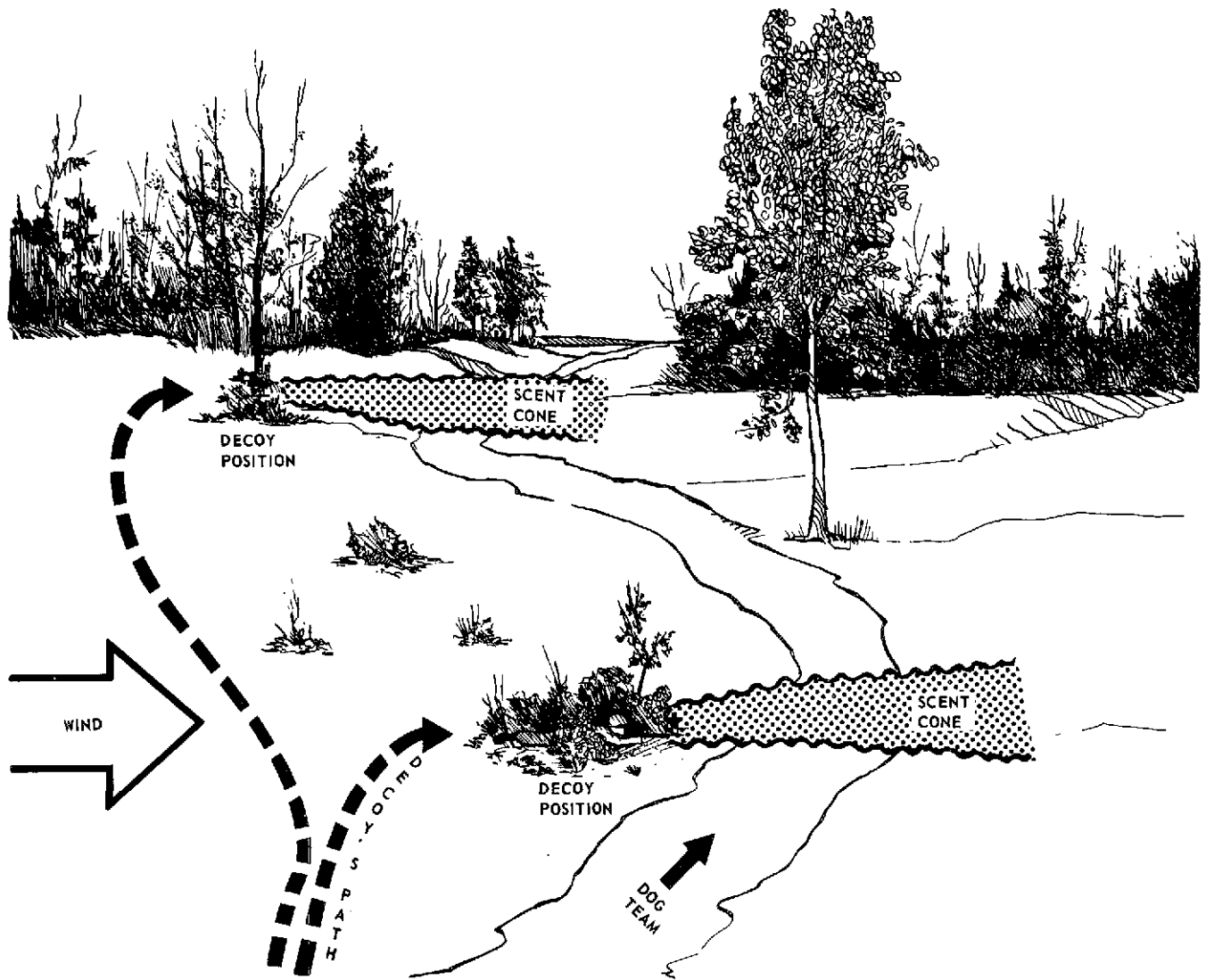

Figure 25—Continued.

Section IV. INTEGRATION OF TRIPWIRES, MINES, BOOBYTRAPS, AND CACHES

48. General

Prior to beginning this training, the handler should have had the opportunity to observe his and other dogs working. By doing this he will learn that each dog reacts differently under various situations, and how his dog reacts. Mines, boobytraps, and homemade devices have been used in warfare for centuries; they can kill, disable, harass, and affect the morale of a fighting unit. Patrols will encounter these devices in combat; therefore, it is imperative that handlers pay strict attention to this training. Although the military dog is one of the most effective means of detecting these devices, and often the only means on hand, the dog is not infallible. It is the handler's ability to interpret and react to his dog's alerts that may mean the success of a mis-

sion. Training in detection of tripwires, mines, boobytraps, and caches is conducted concurrently with basic scouting procedures. For training purposes, the four classes of targets are defined as follows:

a. Tripwires. A length of material stretched across diagonal or parallel to, the dog's path. Material may be standard tripwire, string, or monofilament line. Tripwires may be at varying heights, angles, and degrees of concealment.

b. Mines. Simulated or real (defused) anti-tank and antipersonnel mines will normally be buried in road surfaces or shoulders at depths varying from 1 to 12 inches and with varying degrees of concealment.

e. Boobytraps. Explosive or nonexplosive cas-

uality producing devices other than mines. These are normally pyrotechnics or defused hand grenades. When not attached to tripwires, boobytraps may be hidden or buried at bridges, logs, doorways, gates or other suitable locations.

d. Caches. Any item of military-related equipment hidden at, above, or below ground level. Items may include weapons, ammunition, clothing or web gear.

49. Introduction to Tripwires

Tripwires present some unique problems in training scout dogs. The most important factor is to instill in the dog a reasonable caution towards tripwires. Since most dogs will have a natural suspicion of anything across their path, improper technique can change this to fear. For this reason exploding devices are not attached to tripwires until advanced training. A dog which has had several boobytraps blow up in its face may become trail-shy and refuse to work. On the other hand, if a dog is taught no respect for tripwires, it may accidentally break them, or even do so deliberately to show its handler it has found one. A prudent balance must be made between desire

to find tripwires and caution about touching them.

50. Tripwire Lanes

When first introducing tripwires, special lanes should be used. These may be narrow (6 to 10 feet) dirt roads or lanes cut across fields. Each lane should contain five to ten movable stakes at least 3 1/2 feet long, with nails or hooks every 6 inches apart for a length of 3 feet; the wires are placed at varying distances and heights. Tripwire at this point should be heavy white string (easily visible) with weights on both ends to hold it taut (fig 26 and 27). The strings should be placed on different stakes for each dog.

51. Tripwire Training Device

Some dogs may have difficulty with early tripwire training, or may wander off the lanes and bypass tripwires. In this case, a simple training device may be constructed of lumber (fig 28). The device should consist of two rails, 24 feet long and 3 feet high, with posts every 3 feet. Tripwires can be attached to the posts as with the stakes on the lanes. This device is used in

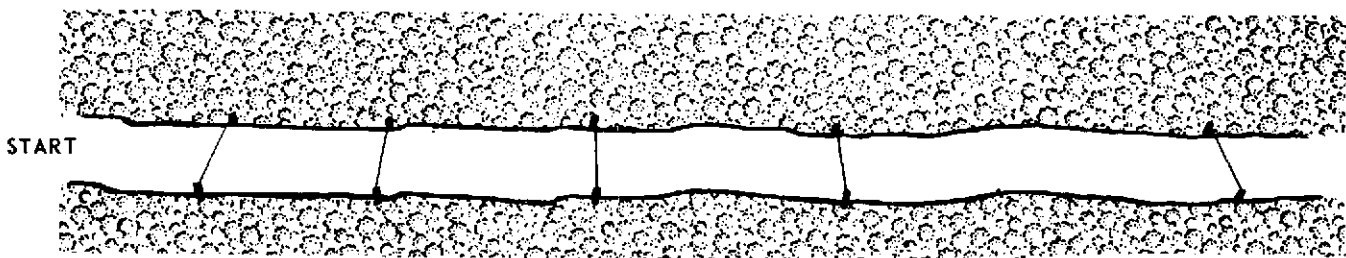

Figure 26. Tripwire lane.



Figure 27. Tripwire hookup.

the same manner as the training lane, but restricts the dog's attention to its immediate environment. If desired, the rails may be covered on the outside with chicken wire and gates may be added.

52. Method

a. Step 1. As described previously, the search chain substitution procedure is used. Initially, each dog can be worked on one tripwire, placed about 10 feet from the starting point and 1 foot high. The dog is first introduced to the string with the feed pan partially under the string and the dropper behind the string (fig 29). The search chain is employed, with the dog going to the pan, eating the food and returning to the heel position. This will acquaint the dog with the string without instilling fear, and condition it to stop at strings or wires.

b. Step 2. Repeat step 1 with the pan centered under the wire. The distance of the string from the starting point is increased until the dog consistently goes through the search chain the full length of the lane.

c. Step 3. The feed pan with one cube in it is placed 1 to 2 feet beyond the wire, which is in

the same position as in step 1. Here it is advisable to use three strings at 6, 12, and 18 inches, to discourage the dog's jumping the wire to get at the feed pan. The handler will follow his dog closely as it moves out. As soon as his dog gives the slightest indication of hesitation at the barrier, the handler reinforces with "Good," and the dropper shoves the pan under the wire to the dog. The dropper **MUST MAKE NO MOVE TOWARD** the feed pan until "Good" is said. Continue this procedure until the dog goes to the barrier and waits for reinforcement. Gradually reduce the number of wires to one, and begin varying the wire height and distance.

d. Step 4. Fade out the feed pan and dropper. To begin the handler will give food by hand on every other trail. Gradually increase the ratio of hand-to-pan delivery until all food comes from the handler. At the same time, the dropper will gradually move away from the wire until he is out of the immediate training area. When this is accomplished, the feed pan is removed.

e. Step 5. As the pan and dropper are being faded out, begin incorporating the sit response at the tripwire. As soon as his dog stops at the wire, the handler gives the sit command, fol-

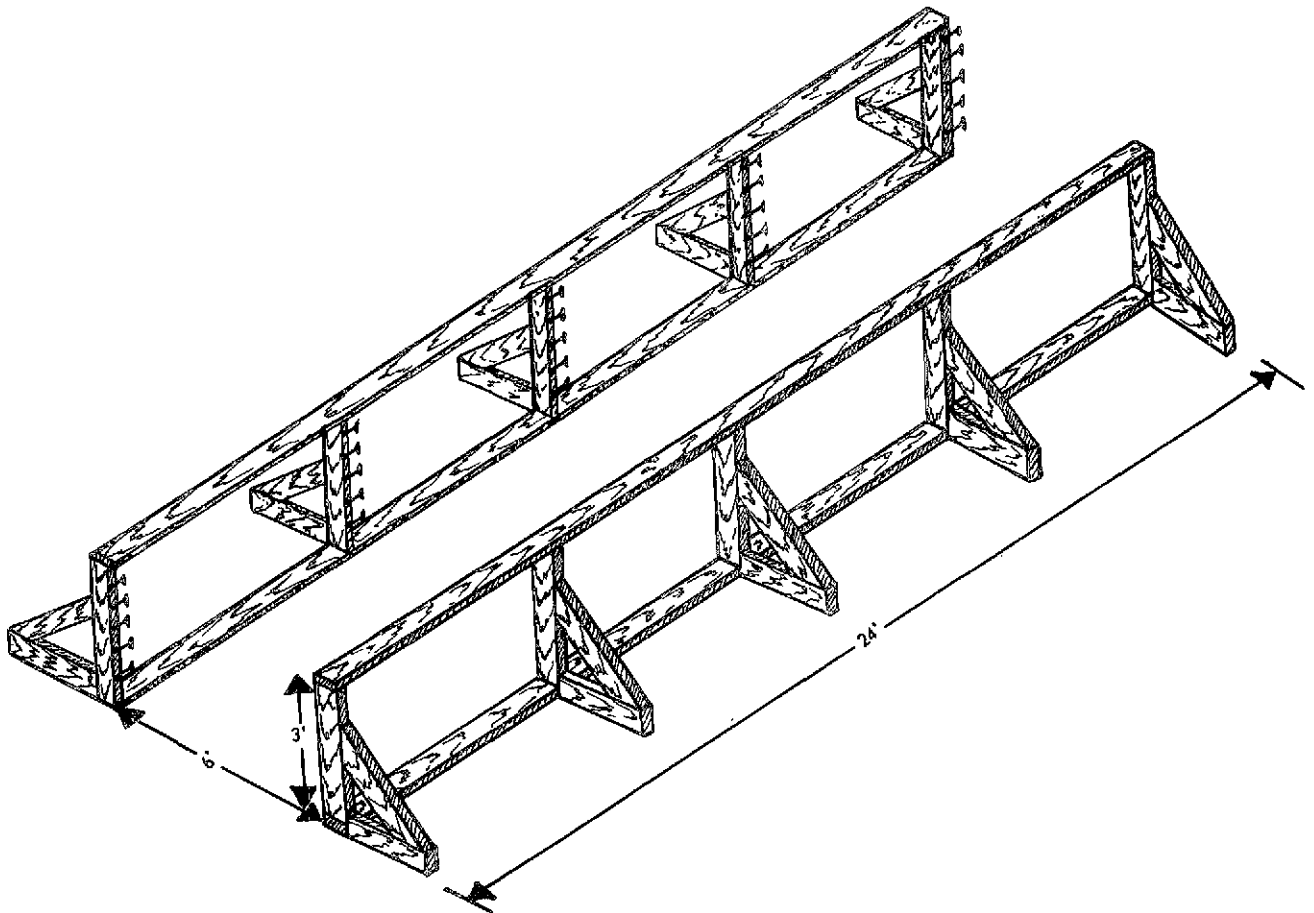

Figure 28. Tripwire training device.



Figure 29. Feed pan under white string.

lowed 1/2 second later by a light touch on his dog's croup. When the sit movement is complete, the handler reinforces. This procedure is continued until the dog consistently goes to the wire and sits without command.

f. Step 6. Begin delaying reinforcement of the sit response. When the dog sits, the handler gives the stay command. After 1 to 2 seconds, if his dog remains sitting, the handler reinforces. Continue until the dog remains sitting up to 5 seconds before reinforcement. From this point on, dogs should always be required to sit at least 2 seconds before reinforcement. This practice will later insure that a dog's alert is pinpointed and observed by all members of a patrol.

g. Step 7. Gradually introduce other tripwire materials, making them increasingly difficult to locate by eye. Vary height, distance, and angle from one lane to another.

h. Step 8. Concurrently with step 7, the handler will begin having his dog complete the search chain with tripwires. He allows his dog to go to the wire and sit. After 2 seconds, he recalls his dog to the heel position before reinforcing.

i. Step 9. Move from the tripwire lanes to open roads, trails, and fields. All wires are now attached to natural objects; begin with white string and change to other materials. Most dogs will quickly learn to recognize cues telling them tripwires may be nearby. Since the strongest cue is the "track" left by the emplacer as he strings the wire, this track should initially be quite obvious. Other cues include: the scent of the wire or the device attached to it, the disturbances at the ends of the wire, visual observance, or even the sound of a taut wire vibrating in a strong breeze.

j. Step 10. Introduce off-trail, multiple, low and

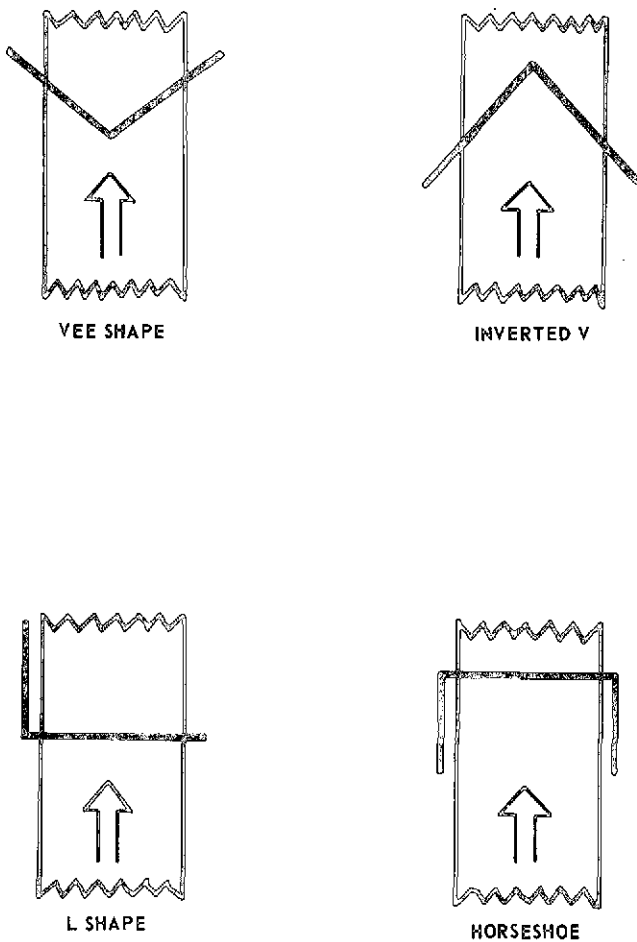

Figure 30. Tripwire variations.

high wires. Off-trail tripwires are emplaced 1 to 20 feet from the edge of the lane, up wind of and parallel to the dog's line of march. Multiple settings may be two, three, or more wires strung in varying shapes (fig 30) and angles. Low wires may be 1 to 2 inches above the ground. High wires may be 4 to 5 feet above the ground.

53. Mines

Scout dogs may be taught to detect buried mines

using the same procedure as pan orientation coupled with substitution in the search chain. Initially, the mine will be placed on the ground. The feed pan may be placed next to the mine and later faded out, or the food may be placed directly on the mine. Once the dogs are completing the search chain with mines, the mines can be placed in shallow, open holes. Gradually begin filling in the hole and continue until the mines are completely covered and camouflaged.

54. Boobytraps

In most cases, boobytraps are attached to tripwires and require no special training procedure. It is preferred that the dog be taught to detect and respond to the wire, not the boobytrap. A dog that finds a wire and then searches for the boobytrap may accidentally trip it, and some older dogs will often deliberately set off the boobytrap, hoping that they will be taken off the lane and staked out, thereby getting a free break. Where boobytraps are not attached to tripwires, dogs can be taught to detect them in the same manner as with mines.

55. Caches

Scout dogs may be taught to give either the natural or sit response to caches. The natural response is preferred, since the equipment will probably have a large amount of recent human scent on it, causing the dog to give a personnel (natural) alert. The natural response also offers the handler a means of differentiating these alerts from those on casualty-producing devices.

56. Advanced Training

In the intermediate and advanced stages of training, tripwires, mines, boobytraps, and caches should be integrated into personnel lanes anywhere that it would be tactically logical to do so.

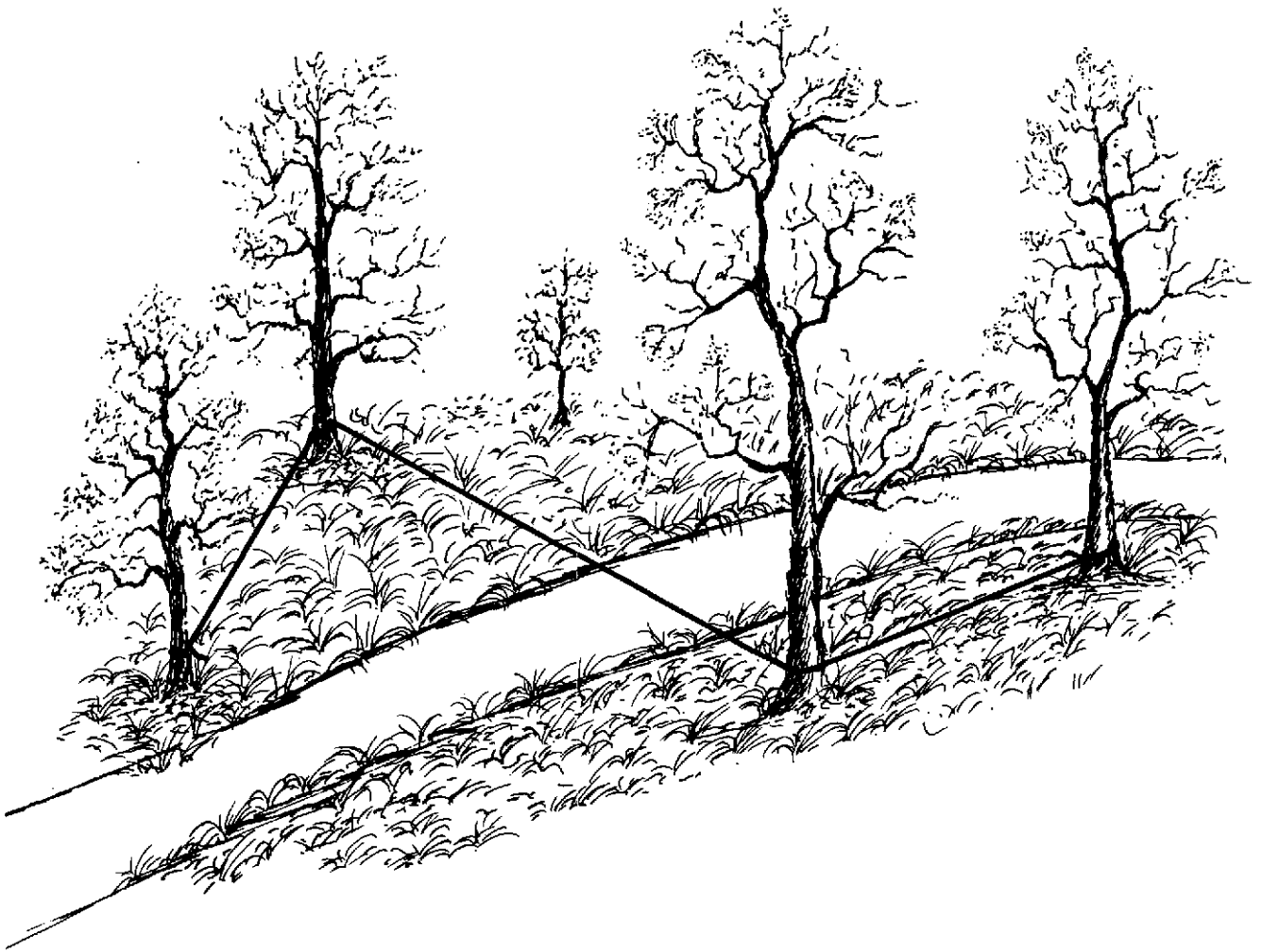

Figure 30—Continued.

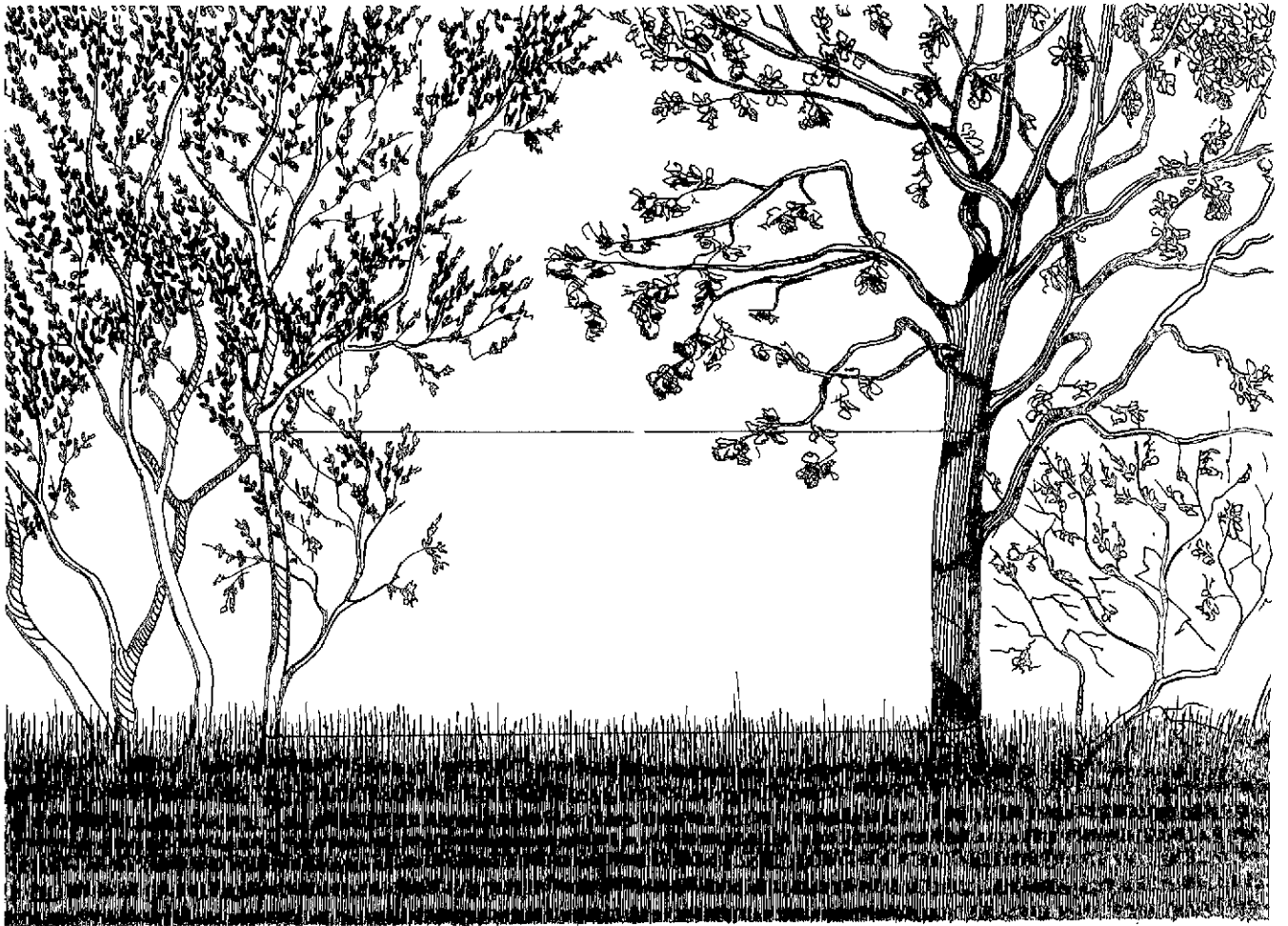

Figure 80—Continued.



Figure 30—Continued.

CHAPTER 5

INTERMEDIATE SCOUTING

Section I. TRAINING CONSIDERATIONS

57. Scope

During intermediate scouting the handler and his dog learn—

a. To increase and expand upon the skills learned in basic scouting.

b. To work medium distance patrols of 500 to 1,000 meters.

c. To recognize and detect various types of tripwires and boobytraps, all of which are partially-to-well-concealed.

d. To detect personnel and equipment hidden underground, above ground, and underwater.

e. To work at night. The handler learns to recognize and interpret his dog's actions and responses at night.

f. During intermediate scouting the handler and dog begin to function as a team. The handler will obtain almost complete control of his dog by use of voice commands, hand and arm signals, and the dog whistle. They will operate under conditions more closely simulating combat.

58. Calling Alerts

Calling or interpreting his dog's alerts may well be the handler's most important function as a member of a scout dog team. Any member of a patrol can probably give the dog commands, and the dog may even work for him. This, however, is not sufficient. It is the handler's ability to translate his dog's actions into information that makes these actions valuable. To do this, the handler must perform a sometimes complex mental operation. The process may work as follows:

a. The handler recognizes that his dog has alerted.

b. The handler recognizes the type of alert.

c. The handler observes and analyzes the wind,

weather, and terrain factors bearing on his dog's alert.

d. The handler considers those elements of available intelligence and information which may bear on his dog's alert.

e. The handler combines the above into a clear, concise statement that a patrol leader or unit commander can use immediately. An example of such a statement might be: "Sir, my dog has given a strong personnel alert between 1 and 3 o'clock. The distance is 200 to 250 meters. I suspect eight to ten dismounted enemy personnel." Another example would be: "My dog is alerting between 11 and 1 o'clock, at about 15 meters. I suspect a tripwire across the trail."

59. The Clock System

Scout dog handlers use the clock system to estimate the direction of their dog's alerts. In doing so, the handler imagines himself standing at the center of a standard clock face, with his direction of march representing the noon or 12 o'clock position (fig. 31). When his dog alerts, he observes the direction of alert and goes through the mental process described in paragraph 58. When the handler is sure he has determined the correct direction, he selects the appropriate half-hour mark and "calls" the hour positions to either side (fig 32). For example, if the handler decides that his dog is alerting at 1: 30 on the clock, he will call his alert as being between 1 and 3 o'clock. This process is done mentally and verbally: **THE HANDLER NEVER POINTS IN THE DIRECTION OF AN ALERT!**

60. Range Estimation

In order to estimate the distance to the object of his dog's alert, the handler combines standard range estimating techniques with—

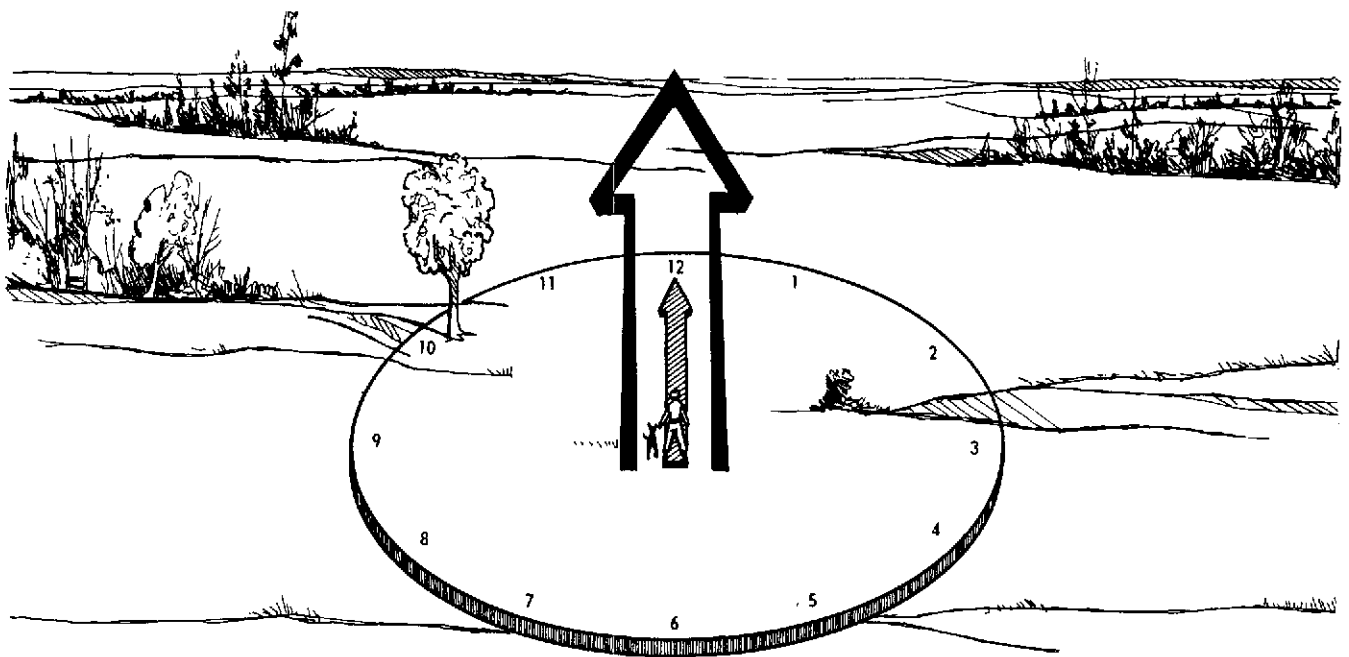

Figure 31. The clock method.

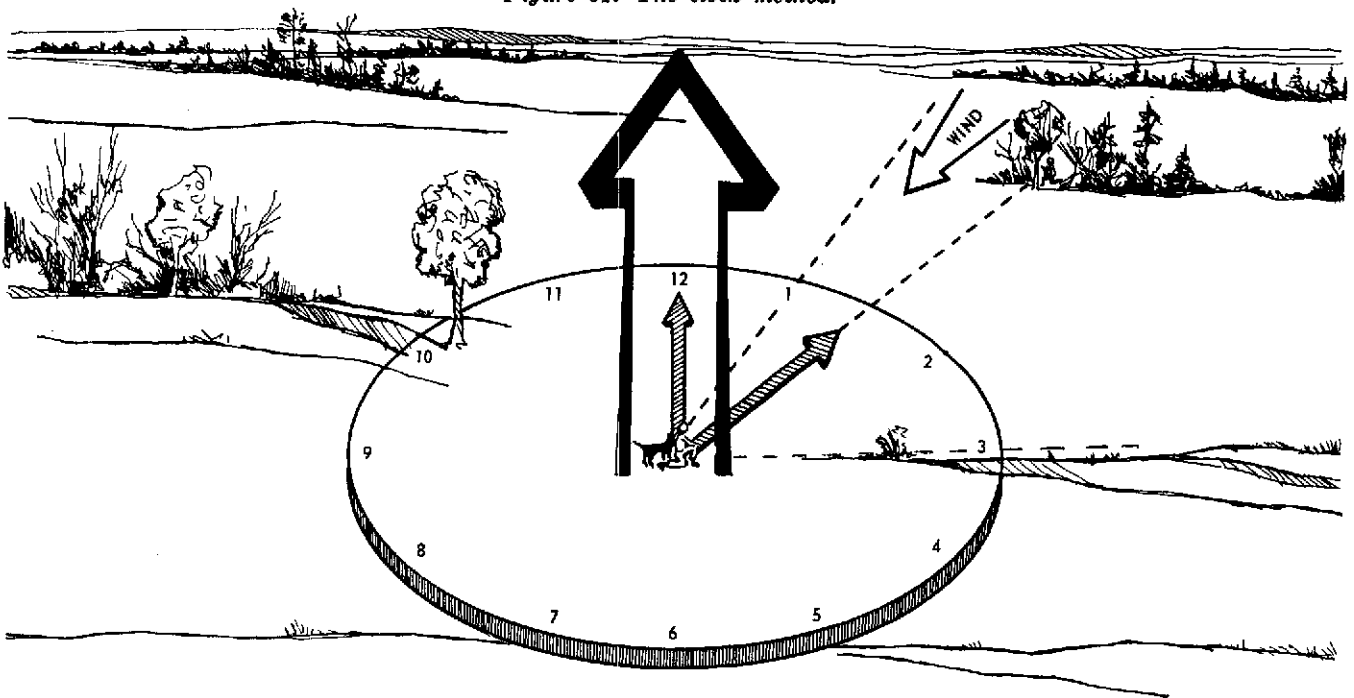

Figure 32. Calling alert by the clock method.

- a. The strength of the prevailing winds.
- b. His knowledge of the effects of visible terrain on the wind.
- c. The strength of his dog's alert.
- d. His knowledge of how his dog reacts to different targets.

Section II. EFFECTS OF WIND AND TERRAIN

61. Effects of Wind

a. Wind is the most important consideration in the proper employment of a scout dog. The wind carries scents and sounds to the dog. Denied the advantage of the wind, the effectiveness of a

scout dog team is diminished. Whenever possible, a scout dog team should be employed to take advantage of the wind.

b. Wind produces what is known as a scent cone (fig 33). Due to the difference in wind velo-

city, strong wind will produce a scent cone that is narrow in width compared to a moderate, steady wind that produces a wider scent cone. A light wind, such as a breeze, due to its lack of force, will cause the scent to drift weakly. Strong, gusty winds, on the other hand, will create ever changing scent patterns depending on the wind's velocity at that particular moment. To quickly and correctly report information provided by a scout dog, the handler must be constantly aware of the direction of the wind.

62. Effects of Terrain

a. Terrain.

(1) Terrain is a determining factor in the direction and force of the wind and a necessary consideration during the employment of scout dogs in order to properly locate the object of the dog's alert.

(2) The only wind that blows steadily is that which comes over a flat and even surface (fig 34). With this condition, alerts of 300 to

400 meters are common, and alerts up to 1,000 meters are possible.

(3) Wind hitting a hilltop or the crest of a hill tends to break into two or three smaller streams of air current (fig 35).

(4) Scents borne by the wind off a mesa may be scattered, blown aloft, or die before they come into contact with ground level (fig 36). A dog may pick up a scent far from a mesa only to lose it upon coming closer to the mesa because the scent is being blown over the dog's head.

(5) Wind blowing from open terrain and up and over a hill, pass, cut, or mesa may carry a scent from the base or from some distant place. The dog may show some confusion when arriving at the edge of such a terrain feature (fig 37).

(6) Dense jungles will restrict the travel of scent considerably, causing it to drift aimlessly due to the general lack of air circulation in such areas. An alert range of 15 to 30 meters is considered good under such conditions.

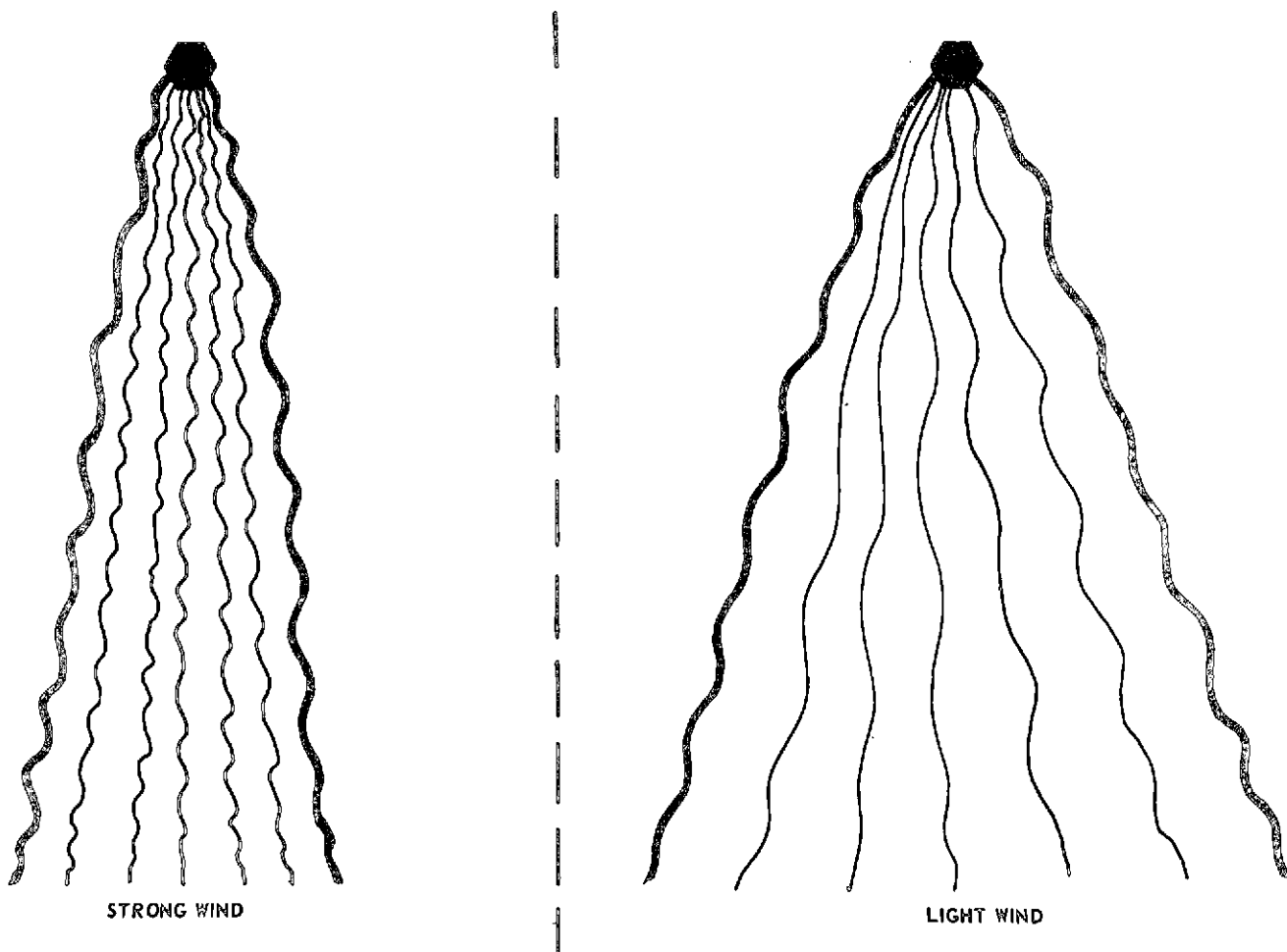

Figure 33. Scent cones.

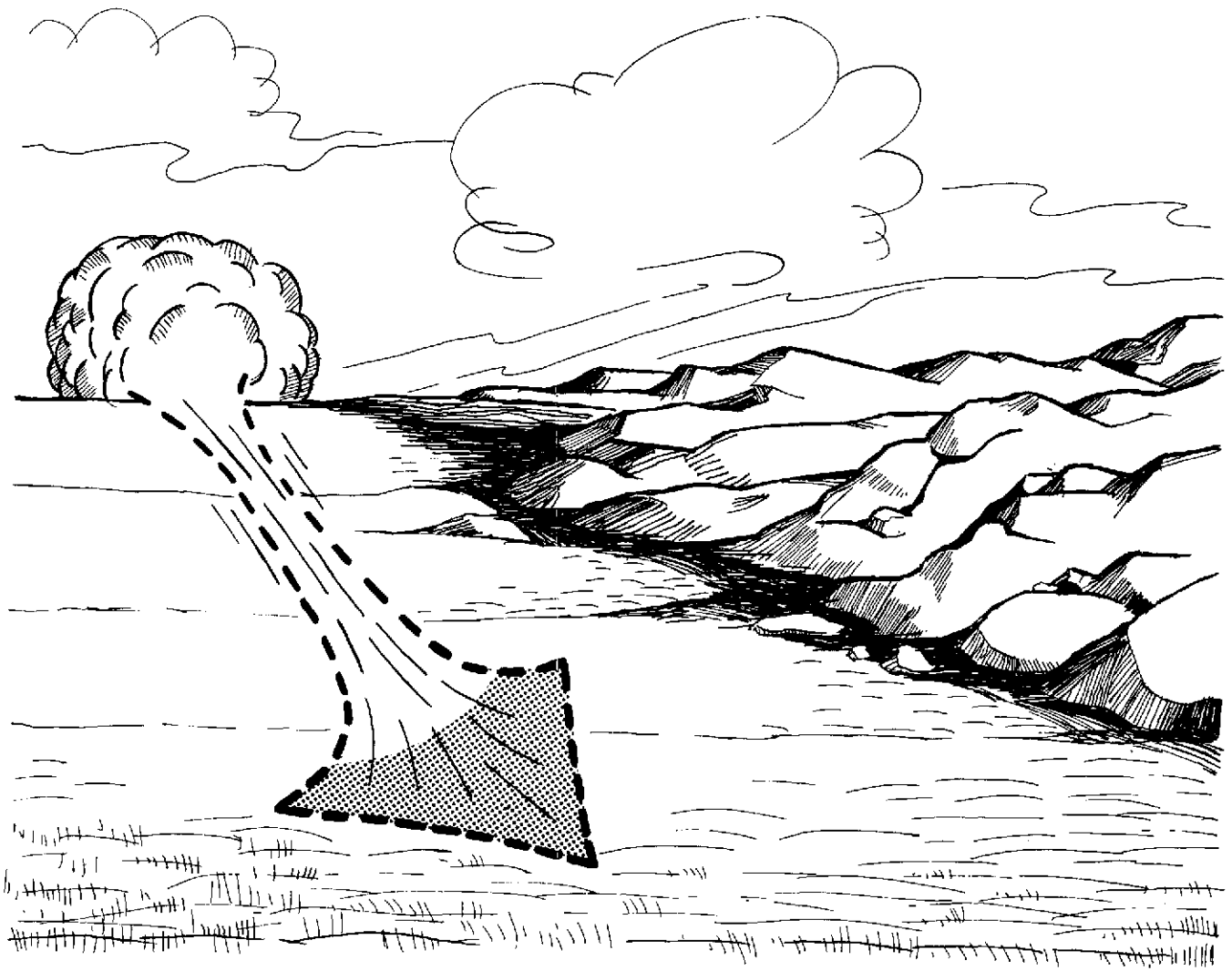

Figure 34. Effect of wind on open terrain.

b. Deflected Scent. Certain terrain situations will deflect the scent cone from a target, causing the need for careful judgment by the handler in calling alerts. Here, his knowledge of wind and terrain factors may be of critical importance.

In figure 38, for example, the scout dog is alerting at 3 o'clock, but the handler should call his alert as "above the ground between 8 and 9 o'clock."

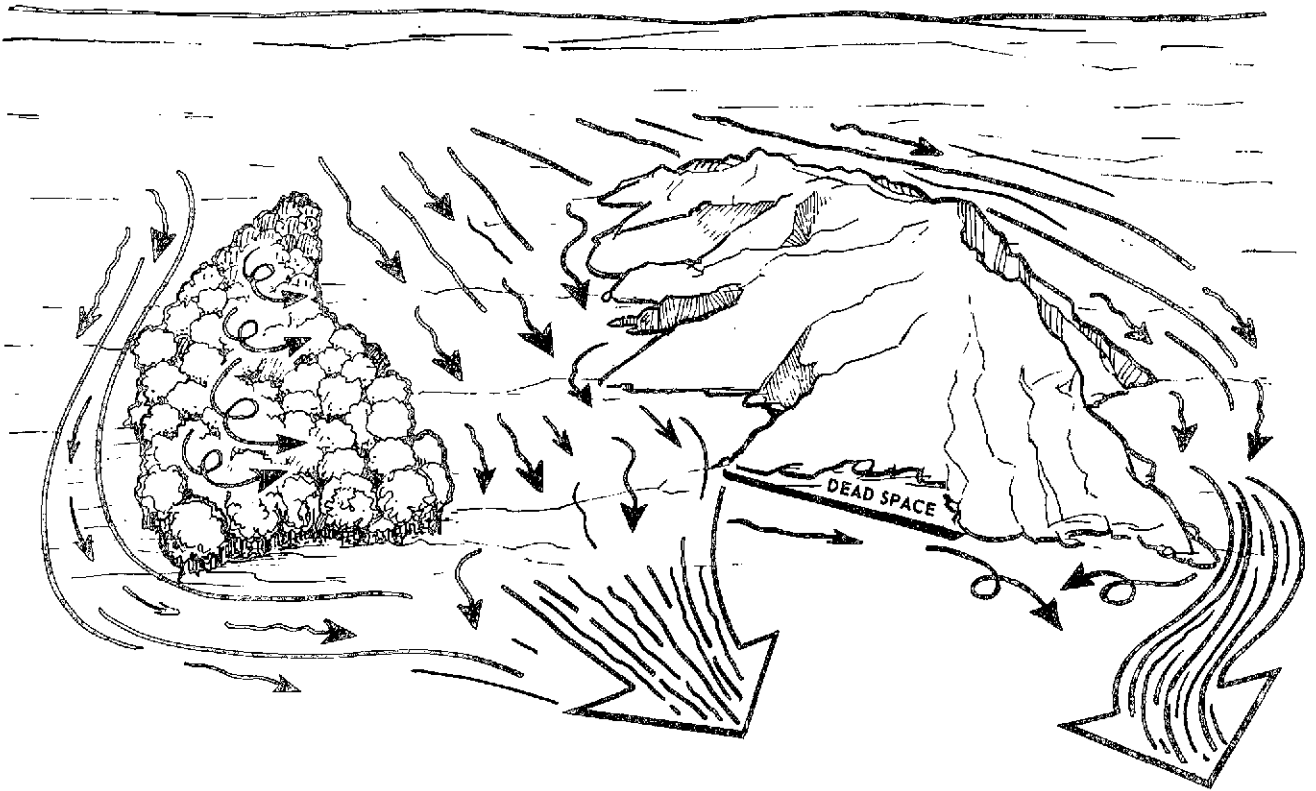

Figure 35. Wind deflection by natural terrain.

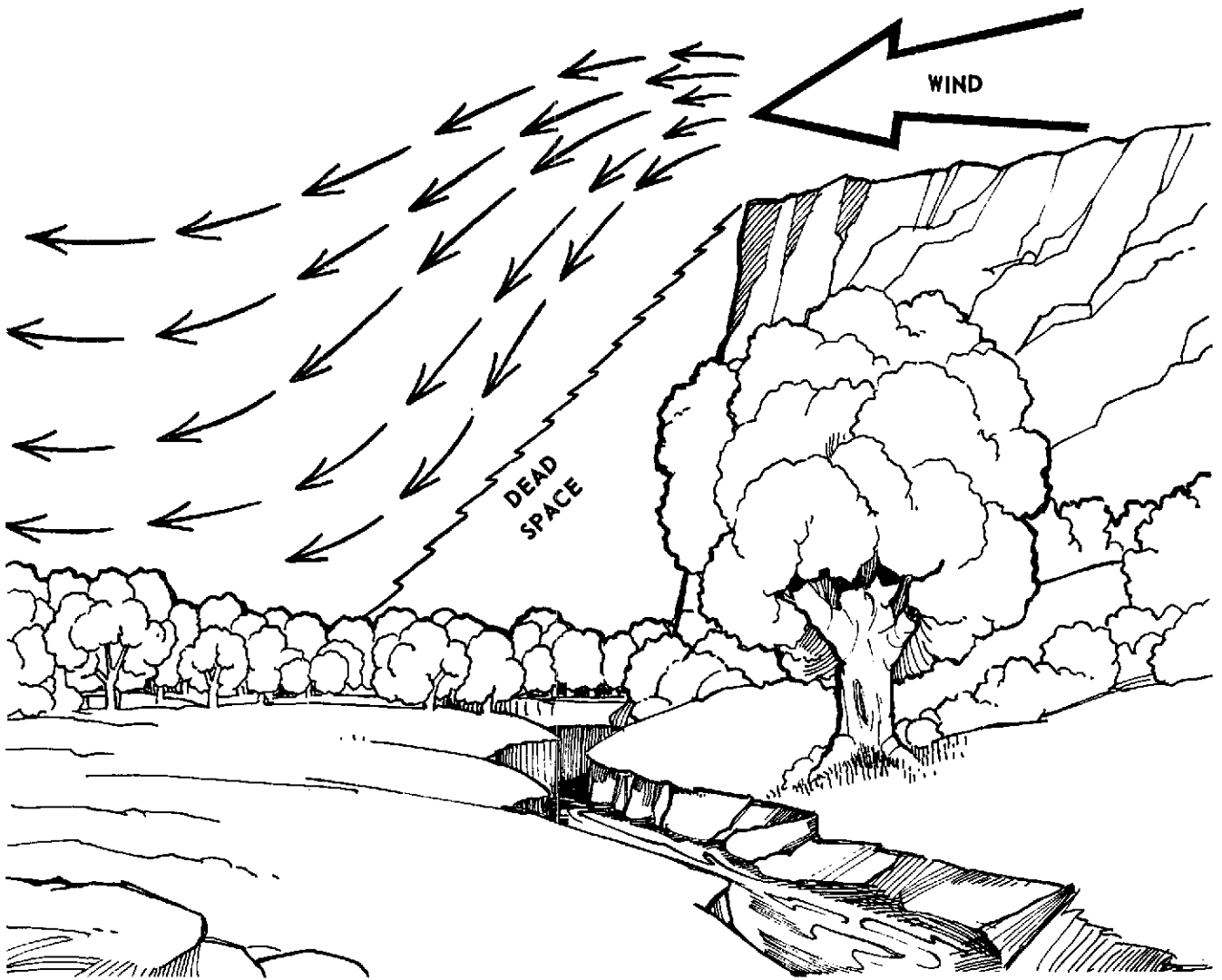

Figure 36. Effect of wind blowing from a mesa.

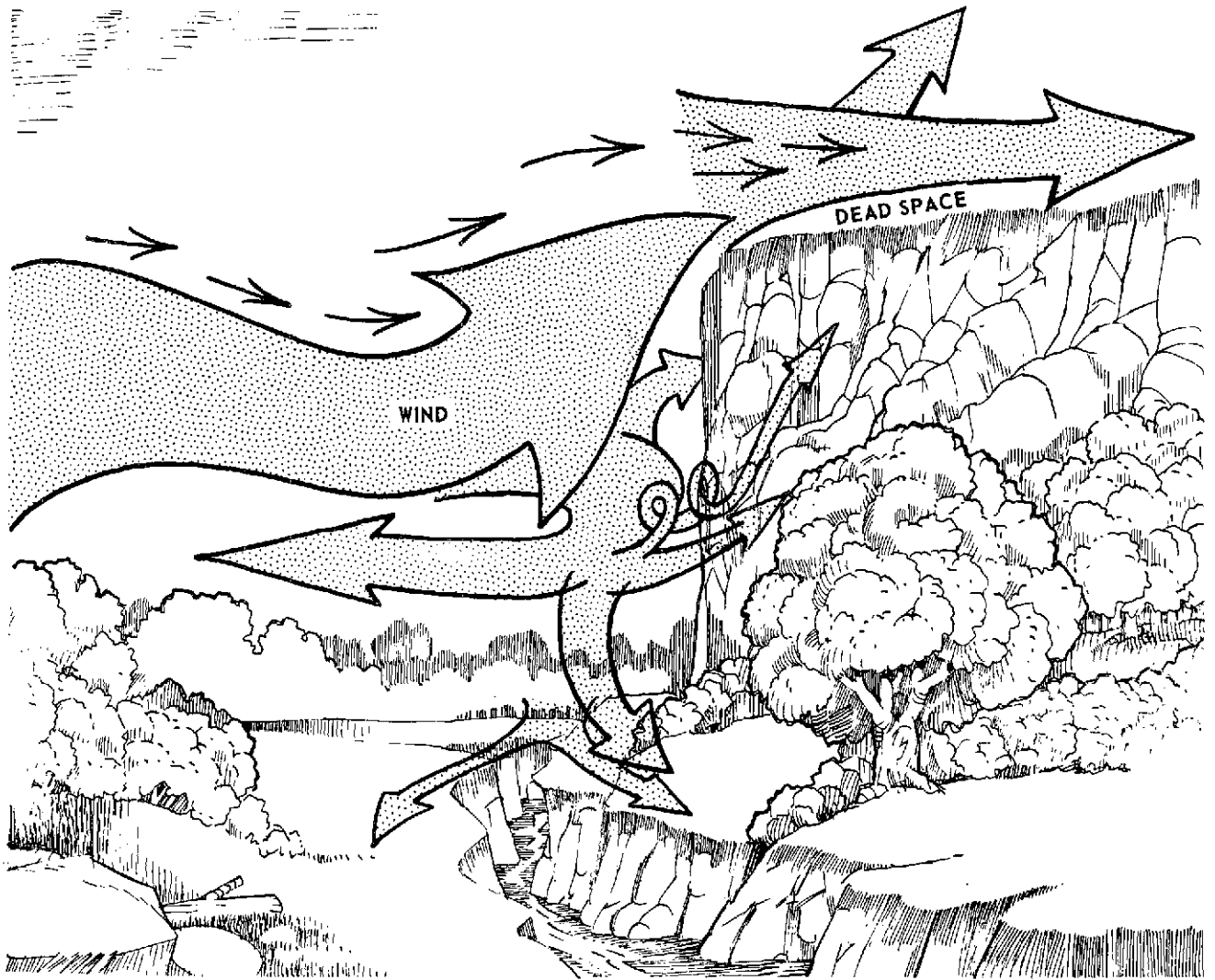

Figure 37. Effect of wind blowing toward mesa.

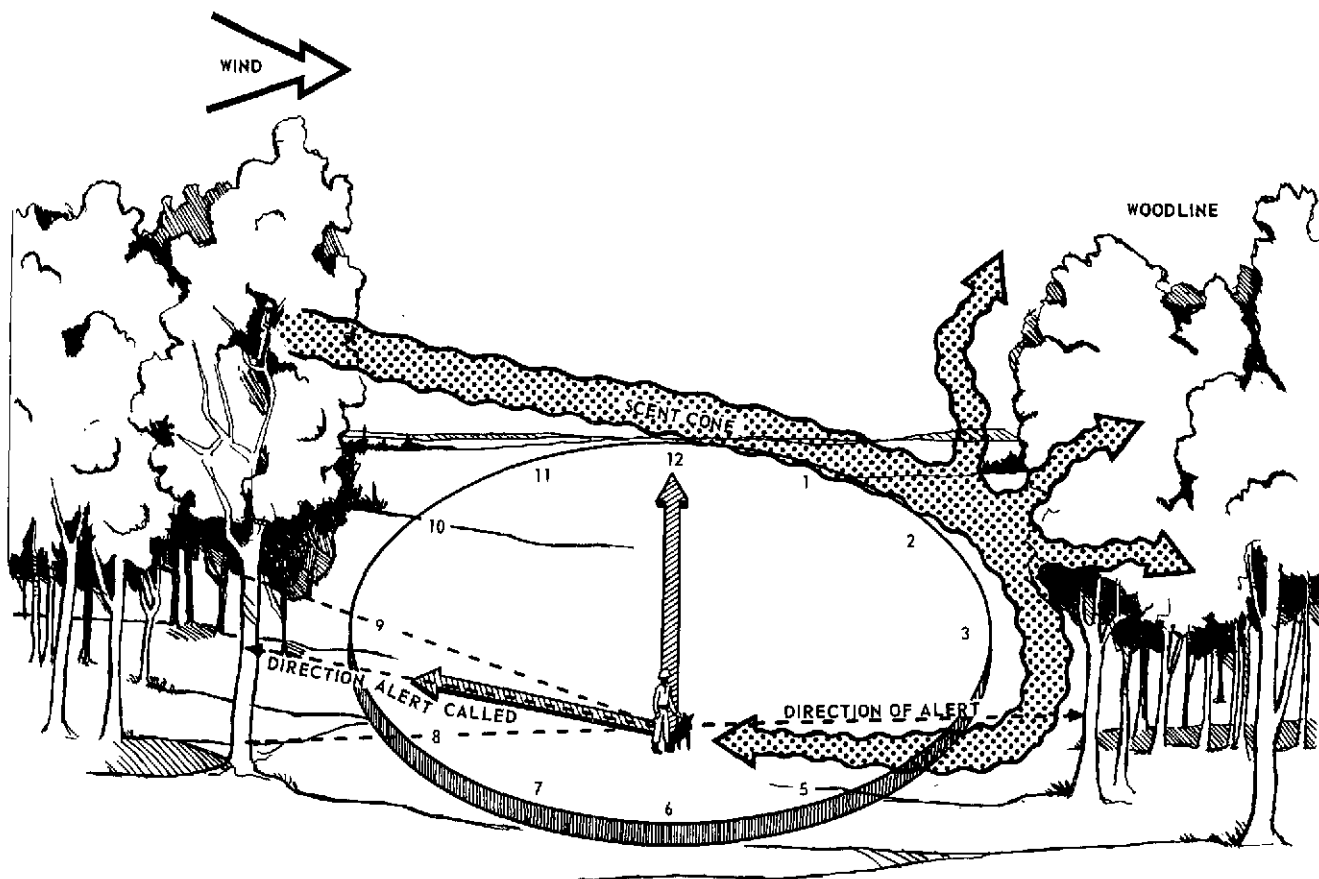

Figure 38. Deflected scent.

Section III. DETECTION OF PERSONNEL AND EQUIPMENT UNDERGROUND, ABOVE GROUND AND UNDERWATER

63. Underground

a. *Phase I.* The same procedure is followed as in the detection of decoys above ground.

(1) Dig a foxhole in open terrain and place a decoy in the position.

(2) After the decoy is in position begin the problem from downwind; as soon as the dog alerts urge the dog to seek out the decoy.

(3) Action taken after the dog has found the decoy:

(a) *Weak dogs.*

1. Sit dog; handler praises dog within sight of foxhole (about 15 feet).

2. Order decoy to come out of foxhole slowly and suspiciously.

3. After decoy emerges from the hole, chase the decoy about 10 to 15 meters, then cut back in the direction previously indicated by the instructor. At this time the command OUT is given, and the problem is continued.

(b) *Strong dogs.*

1. When the dog has alerted the handler it is allowed to go in toward the decoy(s).

2. Every 5 to 10 meters it is commanded to sit, be quiet, and then proceed with the patrol.

3. After a number of repetitions the dog should get the idea and slow down.

b. *Phase II.*

(1) As soon as the scout dogs have progressed, the decoys are placed in foxholes and carefully camouflaged.

(2) The alerts indicated by the dogs are not as strong due to the reduced amount of scent that escapes from air vents.

(3) By this time the dogs should associate the source as coming from underground.

(4) Some dogs will approach suspiciously, while others may stick their noses in the air vents to sample the scent, then they may dig and growl (fig 39).

(5) Some dogs may expect to see a decoy

at the strongest source of the scent and become confused when they do not, while some may run in circles, smelling the ground.

(6) It is at this time that the handler should be alert, observe his dog, and be able to *read* the dog.

64. Above Ground

Detection of personnel or equipment above ground presents some problems due to deadspace. Depending on height, wind strength and direction, and nearby terrain features, the scent cone may reach the ground some distance from the target, or even not at all. Other than sight or sound, there are two means whereby a scout dog can indicate an alert on an above ground target:

a. If a dog enters the scent cone, it will often raise its head to sample the air, or it may even start sniffing close to the ground and work its nose upward in the direction of the target.

b. If a dog is in the deadspace, it may be close

enough to the base of the elevating object to detect the scent left where the person(s) climbed the object.

65. Underwater, Riverbanks

Personnel and equipment will sometimes be found in cavities or hollows along riverbanks. Fleeing or escaping personnel may also try to avoid detection by hiding underwater, breathing through a hollow straw or reed.

a. *Training for Detection Along Riverbanks.* Dig a tunnel below the water level of a stream or riverbank and into an underground hideout. Air vents should be dug at an angle (fig 40). The scout dog should be able to detect the scent coming either from the air vent or from the water. When a handler is certain his dog has alerted, he investigates the area and the decoy is told to emerge from the water. This will astonish most dogs at first, but they should soon be eagerly searching for air vents.

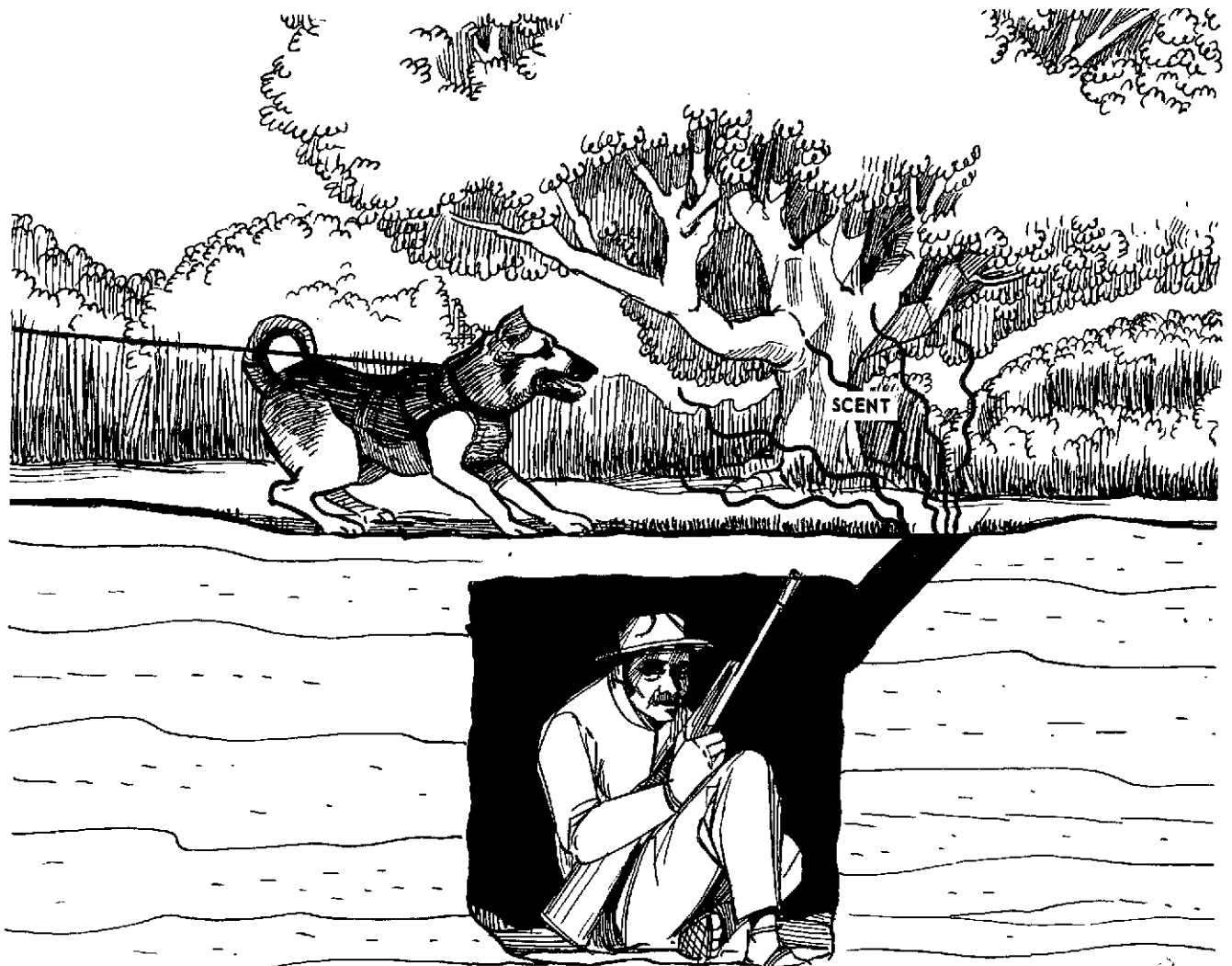

Figure 39. Detection of enemy personnel underground.

b. *Underwater.* Detection of personnel underwater breathing through straws, reeds, or bamboo (fig 41) is not difficult provided the handler can read his dog successfully. Some dogs, upon alerting on live breath scent or dead scent, will become confused when they reach the water's edge. Others will enter the water and start downstream, following the current-borne scent, and lose it. They may then turn back upstream or swim in circles. Occasionally a scout dog, upon

detecting this scent, will stick its head in the water, thinking to see the decoy.

66. Advanced Tripwire/Boobytrap Procedure

During intermediate scouting, instructors should begin teaching that, after finding a tripwire or boobytrap, *the handler should always let his dog lead him around it.* Since another boobytrap may be nearby, this gives the dog a chance to alert.



Figure 40. Detection of personnel under riverbank or canal bank.



Figure 41. Detection of personnel underwater breathing through reed.

Section IV. NIGHT TRAINING

67. Scope

Scout dog teams normally receive three nights of training early in intermediate scouting.

a. The scout dog learns that it must work at night as well as in the daytime.

b. The handler learns how his dog reacts and works at night.

c. The team learns the procedures for employment on outposts, listening posts, and ambush patrols.

68. General

There are a number of advantages and disadvantages to working scout dogs at night.

a. Advantages.

(1) During hot weather, dogs will work better and longer at night, due to the cooler temperatures.

(2) The dog's senses of smell and hearing are heightened at night.

(3) Scout dogs can usually alert at greater distances at night, especially on sound.

b. Disadvantages.

(1) Since the handler may not be able to see his dog's alerts or control it at any distance, he must work his dog on the 5-foot leash. This will reduce the warning distance during movement.

(2) Even on leash, the handler may miss a

personnel alert if he isn't observing his dog carefully.

(3) Some dogs become frisky at night, making undue noise, or may tangle their leashes in brush.

69. Procedure

a. Noise Discipline. Some handlers will discover that their dogs will growl or bark at night. They must learn to quickly stop any noise by their dogs.

b. Each team should be placed in a concealed location, simulating a listening or observation post, along with an instructor. Initially, the de-

coy should approach from some distance upwind, without taking undue care about making noise. This gives the handler the chance to observe both sound and scent alerts. The team should also be exposed to other sounds at varying distances: the click of a rifle bolt, a twig breaking, the clank of untaped combat gear, and other typical sounds.

c. Later, the decoy(s) should approach from various directions and distances, exercising noise discipline.

d. During all phases of night training, the handler must be reminded that, besides watching for his dog's alert, he must be quick to stop any attempted noise by the dog.

CHAPTER 6

SPECIALIZED TRAINING

Section I. GENERAL

70. Purpose

Specialized training is conducted following the completion of intermediate scouting. Its purpose is to give the scout dog team training in overcoming natural obstacles, entering or leaving areas of difficult access, and search techniques in built-up areas.

71. Scope

Specialized training is normally conducted in three concurrent phases:

- a. River crossing.
- b. Rappelling.
- c. Search of built-up area.

Section II. RIVER CROSSING

72. Expedient Methods

There are several expedient methods for crossing rivers or streams.

a. *Fording.* If a wide, shallow (less than 5 feet deep) stream is encountered, a secluded shallow spot for fording should be selected. The dog team should cross first, leading the security or reconnaissance elements. The handler or his bodyguard may probe stream depth with a fathoming stick. If the water is swift-flowing, a safety rope should be secured on both banks, when possible, to prevent men from falling and being carried downstream.

b. *The One-Rope Bridge.* A rope is strung across the stream and pulled as tightly as possible. The dog handler slings his rifle over his back and enters the water with both hands on the rope and the leash tied securely to his leading hand. The scout dog is made to swim in front of the handler. As the handler makes his way across by the rope he always faces upstream in order to detect and avoid floating debris. In this and the other methods, handlers should not try to use their dogs as flotation devices, as some dogs will become frightened and try to escape or even bite. Handlers should also discourage their dogs from trying to climb on them while swimming.

c. *The Australian Poncho Raft.* This raft is constructed by using the equipment of two individuals as follows (fig 42):

(1) One poncho is placed on the ground with the hood facing up and tied off at the neck.

(2) The laces are removed from the boots. The boots and clothing to be kept dry are placed in the center of the poncho.

(3) Packs and helmets are placed on each side of the clothing; web gear is placed on top of the clothing.

(4) The rifles are placed on each side of the clothing and equipment with the muzzles pointing in the opposite directions, operating rod handles facing toward the center, and front and rear sights padded with socks.

(5) The sides of the poncho are folded over the equipment and snapped together.

(6) Starting at the snapped seam, the poncho is rolled as tightly as possible down to the equipment.

(7) The ends of the poncho are twisted into tight pigtailed and are tied together over the rolled seam with one boot lace.

(8) The second poncho is laid out as the first one was. If more bouyancy is desired, brush may be placed between the ponchos.

(9) The poncho bundle is placed, pigtailed down, on the second poncho.

(10) The sides of the second poncho are folded over the equipment bundle, snapped together, rolled, and tied off as before with another boot lace.

STICKS USED IN LIEU OF RIFLE
ACCORDING TO TACTICAL SITUATION

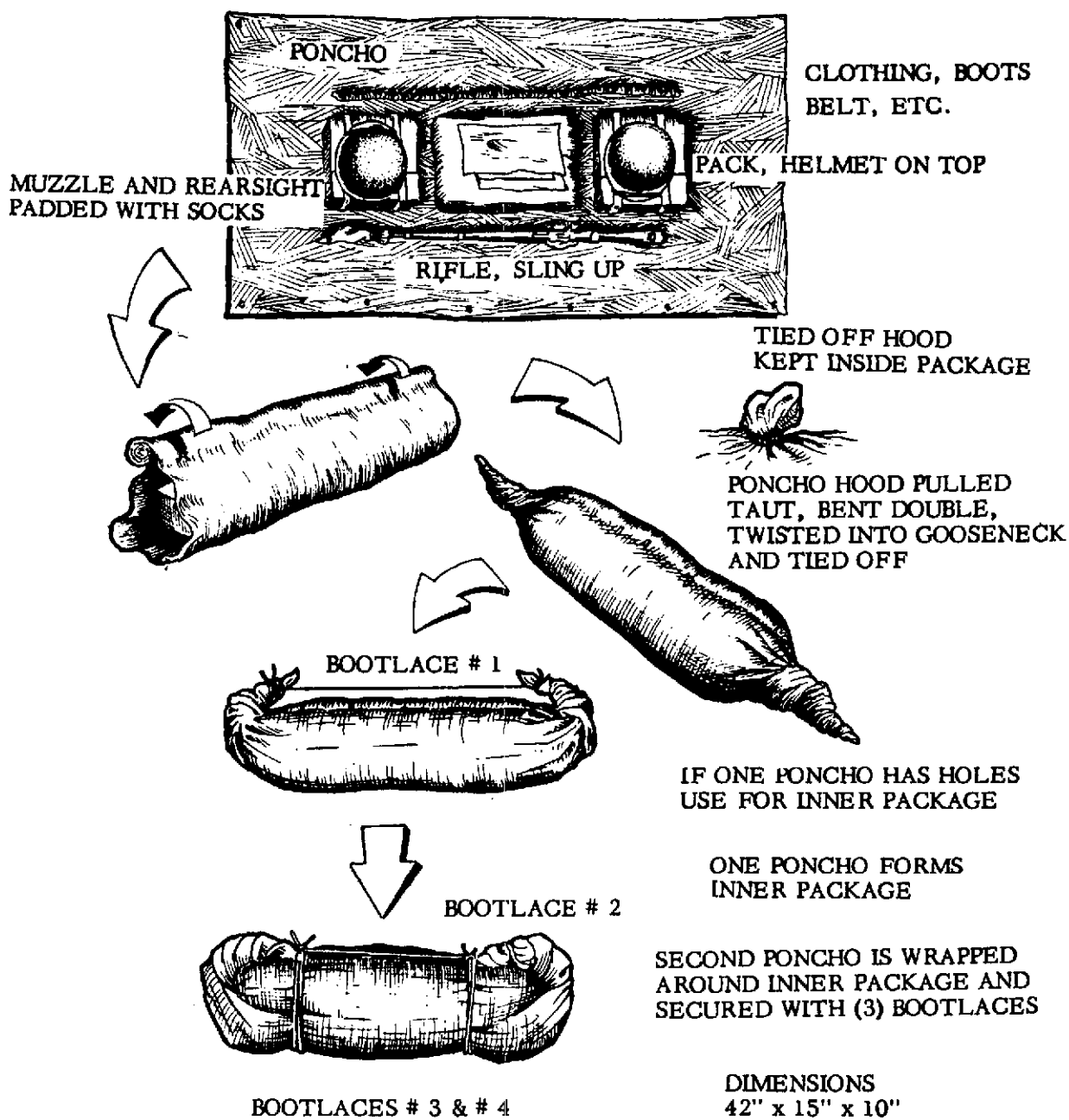

Figure 42. Australian poncho raft.

(11) The other two boot laces are tied around the ends of the raft to further secure the ponchos.

d. Other River Crossing Expedients.

(1) Ammunition cans may be tied to the ends of a pistol belt and used as water wings.

(2) Five empty canteens tied to each end of a pistol belt and used for support.

(3) Air mattresses may be inflated and used.

(4) Waterproof bags, with equipment and clothing placed inside, can be tied off securely and used to support a person.

(5) An empty water can will float an individual and his equipment.

(6) A pair of fatigue trousers tied off at each of the ankles can be inflated and used as water wings.

73. Crossing Thickly Vegetated and Swampy Areas

Conditioning the mind and body to accept dense vegetation and mucky underfooting is the key to crossing this kind of obstacle effectively. On-the-job training is the only way to gain this kind of

conditioning. Handling a dog while wading through a swamp can be a difficult ordeal. Fre-

quent marches through dense vegetation and swamps do much to condition handlers and dogs.

Section III. RAPPELLING

74. Rappelling

a. Team Rappelling. The teams can descend upon obstacles quickly by means of a rappel, sliding down a sling rope which has been doubled around rappel points (trees, projecting rocks).

b. Establishing a Rappel.

(1) In selecting the route, be sure the rope reaches the bottom or a place from which further rappel can be accomplished.

(2) The rappel point should be tested carefully and inspected to see that the rope will run around it when one end is pulled from below, and that the area is clear of loose rocks or debris.

(3) If a sling rope is to be used for a rappel it should be tied twice to form two separate loops.

(4) The first man should—

(a) Choose a smooth route for the rope, free of sharp rocks.

(b) Place loose rocks, which the rope might later dislodge, out of the way.

(c) See that the rope will run freely around the rappel points when pulled from below.

(5) Each man down will give the signal *Off Rappel*, straighten the ropes, and see that they will run freely around its anchors. When silence is needed a prearranged signal of pulling on a rope is substituted for the oral signal.

(6) When the last man is down, the rope is recovered; it should be pulled smoothly, to prevent the rising end from whipping around the rope. Personnel should stand clear of the falling rope, and rocks that may be dislodged by it.

(7) Ropes should be inspected frequently if a large group of personnel is rappelling.

(8) To protect the palms of the hands from severe rope burns, gloves should be worn for all rappelling.

c. The Seat Rappel.

(1) This method differs from others in that the main friction is absorbed by a snap link which is inserted in a sling rope seat fastened to the rappeller. This provides a faster and less frictional descent than other methods (1, fig 43).

(2) To attach the seat, the sling rope is placed across the climber's back so that the mid-

point (center) of its length is on the hip opposite to the hand that will be used for braking. An overhand knot is tied in front of the body. The ends of the rope are brought between the legs (front to rear), around the legs and over the hips, and tied with a square knot and two half hitches on the side opposite the braking hand (2, 3, fig 43). The snap link is placed through the single rope around the waist and through the overhand knot. The snap link is inserted with the gate down and the opening toward the body. The snap link is then rotated one-half turn so that the gate is up and opens away from the body.

d. The Seat Hip Method.

(1) The rappeller stands to one side of the rope (when braking with the right hand on the left side, and when braking with the left hand on the right side) and snaps the rope into the snap link. Slack between the snap link and the anchor point is taken up and brought underneath, around and over the snap link, and snapped into it again. This results in a turn of rope around the solid shaft of the snap link which does not cross itself when under tension (fig 44).

(2) When a single rope is used, two wraps around the snap link are made to increase friction. Facing sideways, the climber descends using his upper hand as a guide and the lower hand to brake. The rope is grasped by the braking hand with the thumb pointing down and towards the body. The braking hand is held behind and slightly above the hip.

(3) Braking action is obtained by closing the hand and pressing the rope against the body. The rappeller should lean well out, at an angle from the point where the rope is secured, and make a smooth and even descent. This method is the least frictional and fastest. However, special care must be taken that the rope is snapped correctly into the snap link to avoid the possibility of the gate being opened by the rope. Loose clothing or equipment around the waist is apt to be pulled into the snap link, locking the rappel. For these reasons the rappeller must be checked carefully before each descent. For other methods of rappelling see FM 31-72, and FM 21-50.

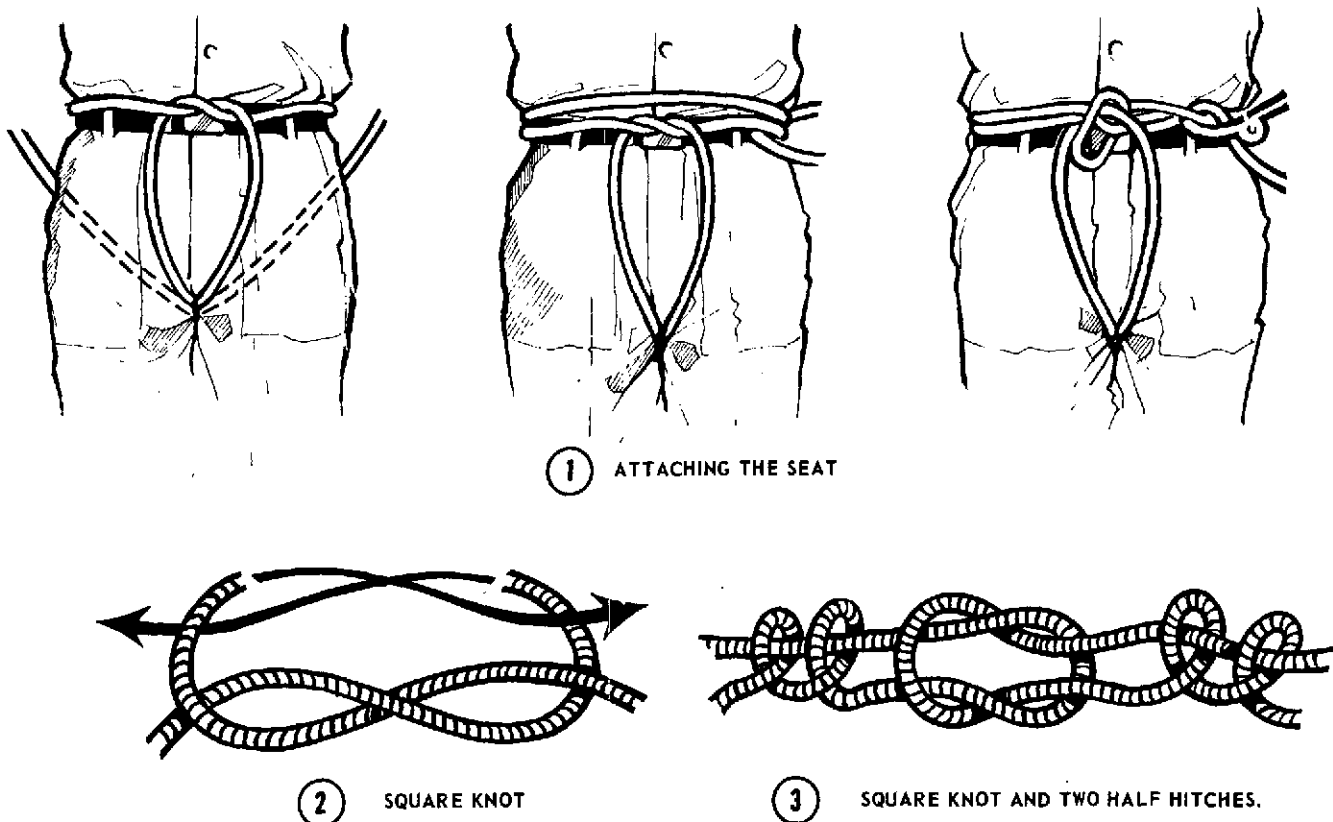

Figure 43. Attaching the seat prior to rappel.

75. Rappelling the Scout Dog Team

The flexibility of the scout dog team to operate in mountains, jungles, or other inaccessible terrain, makes it essential that a team be able to rappel. After the handlers learn to rappel, it is necessary to accustom the dogs to various heights. By the use of pulleys, the dogs can at first be lifted by the use of a scout dog rappelling sling or an expedient sling.

a. The Scout Dog Rappelling Sling. This type rappelling sling (fig 45) can be easily fabricated from durable nylon material (tubular nylon reinforced with nylon thread). A large, medium, or small size sling is made to fit the dog, and is more comfortable than other methods.

(1) First the dog is muzzled; then it steps into the sling with the front loops passing over the head.

(2) The side and back loops are brought together over the dog's back and all snapped into the snap link.

(3) The rappelling rope is then run through the snap link with one turn around the solid

shaft if double ropes are used, or two turns if a single rope is used.

(4) The handler rappels first, then one member of the patrol hooks up the rappelling sling or expedient poncho sling to the rappelling rope preparatory to lowering the dog.

(5) The handler on the ground can slow the descent of his dog by merely pulling on the rope to apply friction.

(6) The handler receives his dog and applies the proper praise.

(7) Most dogs, after a few rappels, learn to accept this training.

b. Expedient Rappelling Sling Using Harness and 5-Foot Leash. This technique is a fast, simple expedient method that requires no special equipment and may be used under nearly all conditions.

(1) *Procedure.* The first step is to insure that the leather harness is securely fastened.

(a) Make a loop by running the free end of the leash through the hand loop. Place this loop over the narrowest part of the dog's body,

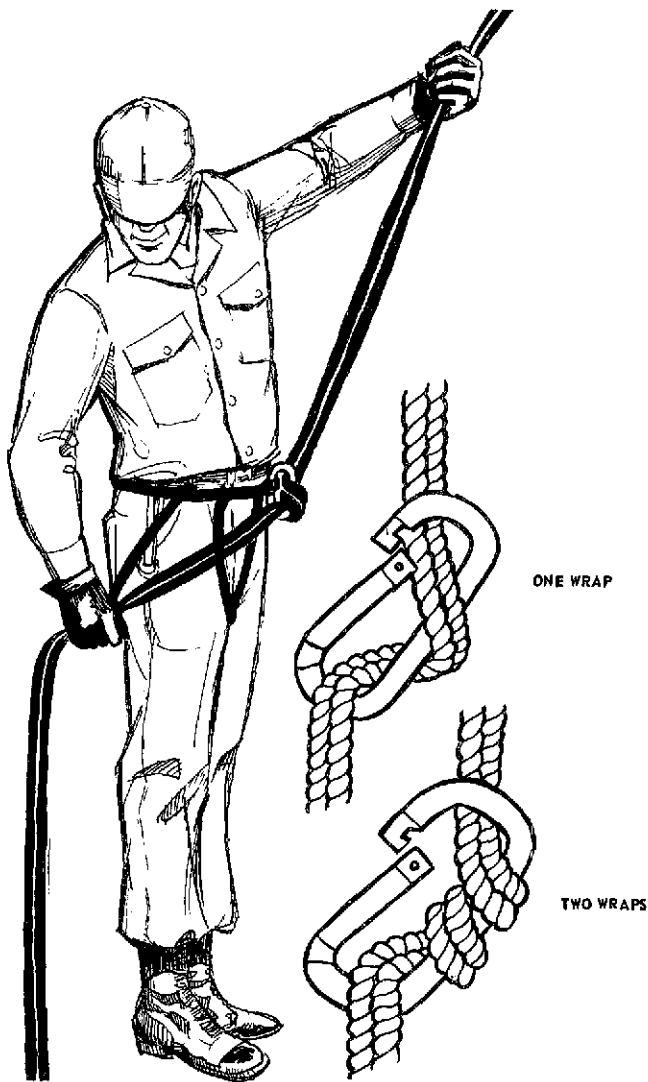

Figure 44. Seat hip method.

between the rib cage and the pelvis. Make the loop snug with the hand loop portion at the spine and the free end running forward (1, fig 46).

(b) Run the free end along the left side of the spine, *under* the rear body strap, *over* the dorsal or upper strap, and back *under* the rear body strap on the right side. Fit snugly (2, fig 46).

(c) Run the free end back along the spine and under the loop (3, fig 46).

(d) Repeat procedure (c) if leash is long enough.

(e) Attach the leash snap to the D-ring on the harness. If necessary, wrap any excess leash around the upper strap until there is just enough left to snap (4, fig 46).

(f) Test the sling by grasping the "handle," formed by the three lengths of leash, and lifting the dog. The dog should balance and feel no discomfort (fig 47).

(g) Attach a snap link to the "handle." It is preferable to attach a second snap link to the first, to allow free play of the rappelling rope (fig 48).

(h) The dog may now be rappelled from or to a helicopter.

(2) *Alternate expedient method.*

(a) An alternate method of rappelling a dog from or to a helicopter is with the use of a duffel bag or mail bag.

(b) *Procedure.* *Back* the dog into the bag. Secure the opening. Attach rope or cable. Lower or extract dog.

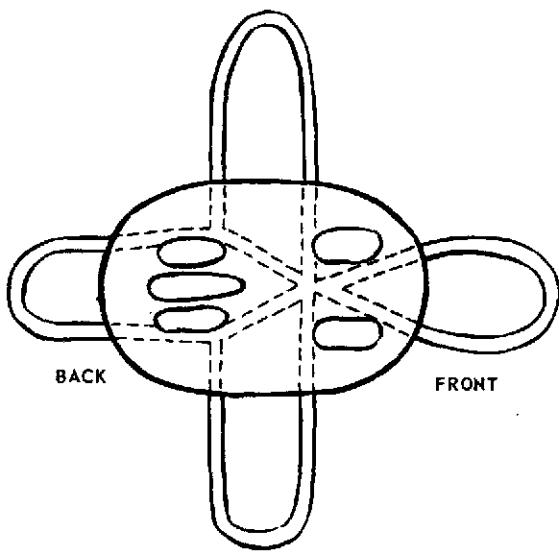

SCOUT DOG RAPPELLING SLING

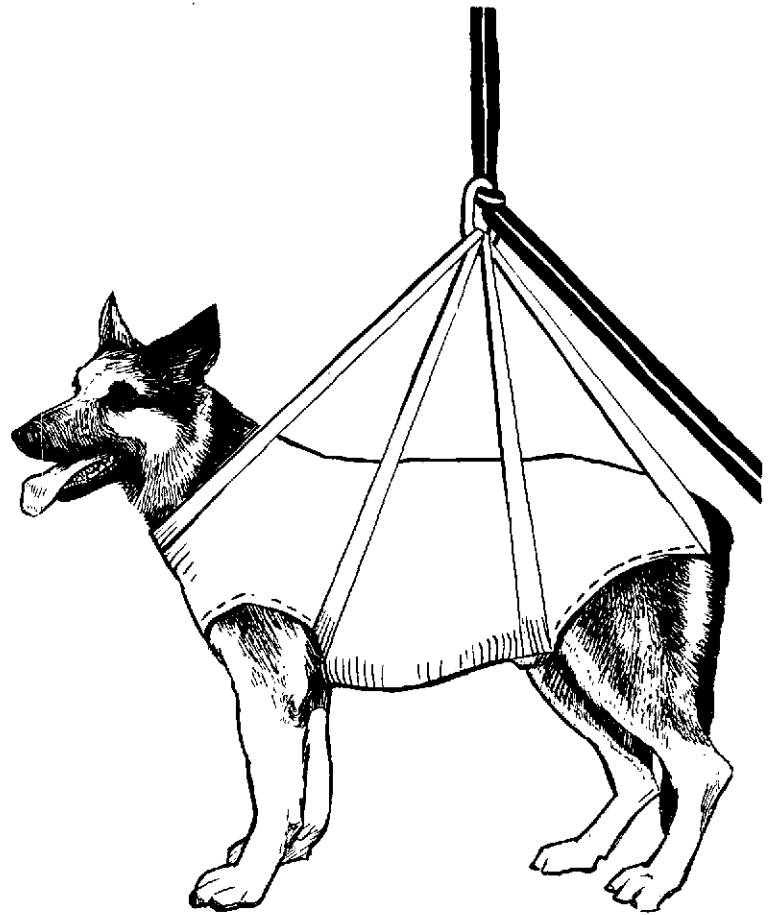

SCOUT DOG IN RAPPELLING SLING

Figure 45. Scout dog rappelling sling.



Step 1

Figure 46. Expedient rappelling sling.



Step 2
Figure 16—Continued.



Step 3
Figure 46—Continued.



Step 4
Figure 46—Continued.



Figure 47. Test sling by lifting dog.



Figure 48. Attaching snap link to harness.

Section IV. SEARCH OF BUILT-UP AREAS

76. General

Searching villages or other built-up areas, with certain exceptions, is little different than other operations. The exceptions are:

- a.* Boobytraps may be found in greater concentration and in unusual locations.
- b.* Inhabitants may distract the dogs.
- c.* Farm or draft animals provide distractions.
- d.* There is a greater than normal concentration of conflicting scents.

77. Rules

In order to overcome the above problems and

facilitate the search, handlers are taught three rules which should be followed whenever it is tactically feasible:

- a.* All inhabitants should be removed from the immediate area while the search is being conducted.
- b.* All animals should either be removed or penned.
- c.* The scout dog team(s) should be assigned a definite search area and pattern.

78. Procedure

It is simplest to use a series of abandoned or unoccupied buildings in a garrison area. Where

such buildings are unavailable, a village can be constructed from available materials, making three or four rudimentary buildings and adding simple artifacts such as fences, gates, pens, haystacks, and the like.

79. Animals

When it is anticipated the scout dogs will be employed in areas containing large numbers of domesticated animals (horses, cows, pigs, goats, chickens) it is desirable to accustom the dogs to such animals during training. The scout dogs may otherwise become distracted or frightened by such animals. Where feasible, a selection of such animals can be procured. Initially, they should be kept in pens adjacent to the kennels, so that the dogs become accustomed to their sounds and smells. During built-up area search training, the animals can be penned in the built-up area to add realism to the training.

80. Villages

At the beginning of this training, one or two decoys and a small number of boobytraps and caches should be concealed in the village so that they are fairly easy to detect. As the teams progress, the number and degree of difficulty of tar-

gets increases. The handler is taught to establish a definite search pattern before entering the village (fig 49). The dog should be worked closely (5 to 10 meters) in front of its handler, or even on-leash where necessary.

a. Perimeter Search. The handler is taught that, if the village is small enough, he works his dog once around the perimeter, allowing it to get the "feel" of the area and a chance to give early warning of any hostile presence within.

b. Building Search. Once the perimeter search is complete, the scout dog team begins its search pattern. The team should try to approach each building from downwind. Each building should be completely circled before entering. If the building is to be entered, the scout dog is given the opportunity to check the entrance carefully for boobytraps.

81. Other Built-Up Areas

The procedures for searching built-up areas other than villages is basically the same as above. Here, the team will be required to search a definite section, such as a few buildings. It is desirable to have at least one two-story building so that the scout dog can gain experience in searching and climbing stairways.

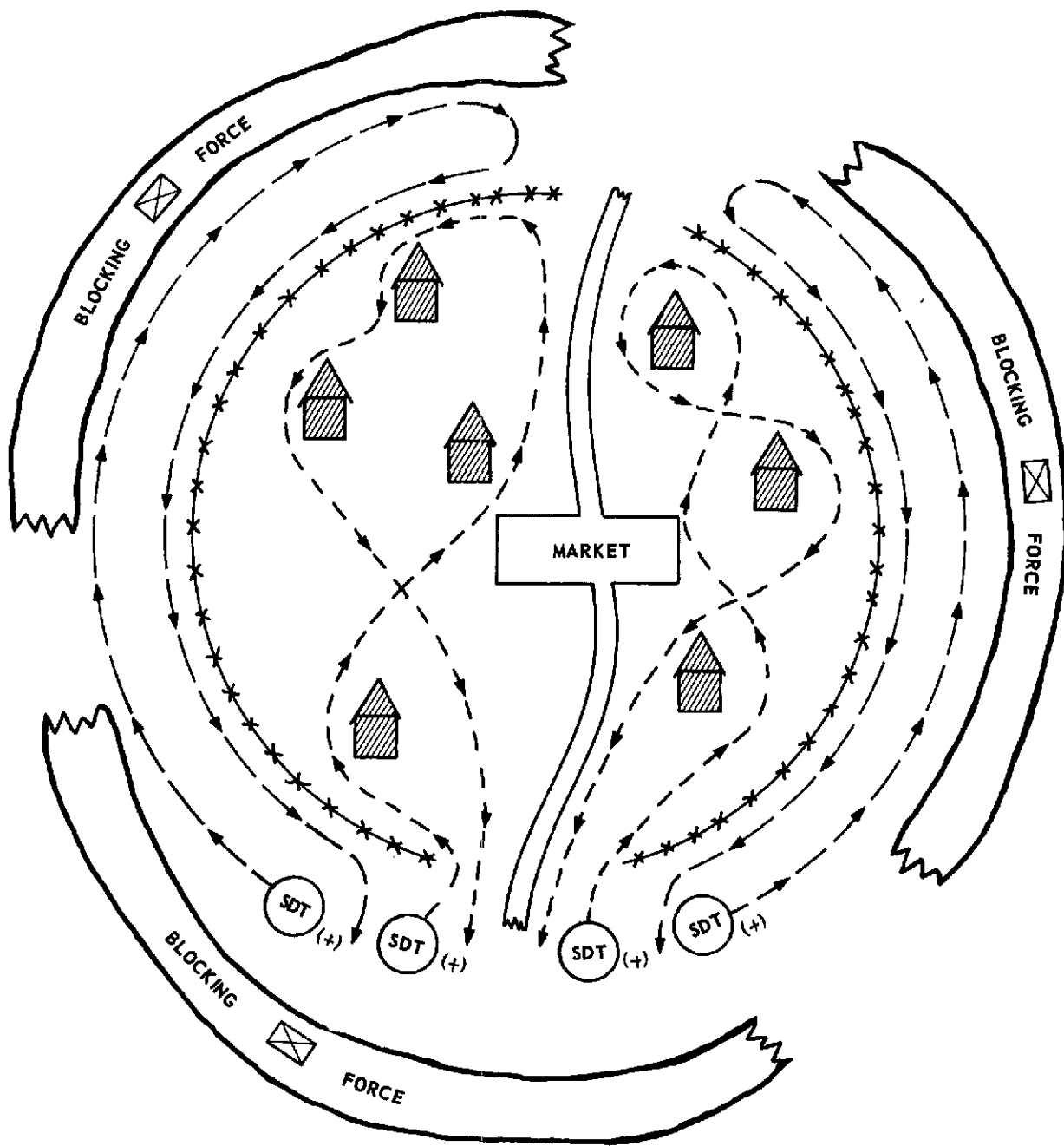

SEARCH (VILLAGES "HAMLETS") OPERATIONS

SDT (+) ONE FIRE TEAM SHOULD GO WITH SDT

Figure 49. Search operations: villages, hamlets.

CHAPTER 7

ADVANCED SCOUTING

82. Scope

During this final phase of instruction, the scout dog teams are no longer being trained, but will apply what they have learned under simulated combat conditions.

a. Most problems will be long range patrols (1,000 to 3,000 meters).

b. Patrols will be over difficult and varied terrain to include swamps, hills, ravines, streams, and dense forest or jungle.

c. All problems will contain decoys hidden at, above, or below ground level, fully concealed mines, boobytraps, caches, and multiple tripwire settings.

d. Some problems should include situations requiring application of river crossing, rappelling, and village search techniques.

e. Advanced night training should consist of night reconnaissance patrols, ambushes, and outposts/listening posts.

f. Problems should include the use of gunfire, artillery and grenade simulators, boobytraps simulators, and other battlefield effects.

83. Preemployment Training

When scout dog teams are to be deployed to a combat zone, advanced scouting should, where possible, be conducted over terrain and under conditions closely resembling the area of operations.

84. Procedure

Students should act as instructors for each other, under the supervision of qualified instructors. Prior to the start of each problem, the student should receive the patrol leader's (instructor's) briefing, then give his patrol briefing (app B). Instructor advice should be kept to a minimum during the patrol. The handler should conduct the patrol as he would in combat, giving

advice about his dog's alerts and, where appropriate, suggesting courses of action.

85. Integrated Support Training

During advanced scouting much mutual benefit can be gained by having the student scout dog teams support the problems of various leader courses. Problems which can be supported include ranger problems, escape and evasion exercises, field training exercises, and squad, platoon, or company tactical patrols. Such integrated training both allows the handler(s) to gain experience in supporting infantry unit operations and gives the leader student(s) experience in the proper employment of a scout dog team.

86. Summary

Prior to the final field performance examination, operational readiness training test (ORTT), or Army Training Test (ATT), scout dog teams should be able to accomplish the following:

a. Handlers should be able to give a clear, concise patrol briefing.

b. Handlers should be able to effectively employ their dogs over all types of terrain, to include river crossing and rappelling operations.

c. Scout dogs should give a natural alert on at least 90 percent of personnel and caches hidden on, above, or below ground level.

d. Scout dogs should give a sit alert (within 2 to 3 feet) on at least 80 percent of all types of tripwires and boobytraps, remaining in position until recalled by their handlers.

e. Scout dogs should work well in front of their handlers (10 to 100 meters, depending on terrain), remaining under strict control, and should be able to safely guide their handlers around tripwires or boobytraps.

f. Handlers should be able to read their dog's alerts to the extent that they can determine the

target's approximate distance and direction within *1 hour* by the clock system, and to state the type of alert.

g. Handlers should be able to effectively employ their dogs on night reconnaissance, ambush patrols, and outposts/listening posts.

CHAPTER 8

EMPLOYMENT

Section I. GENERAL

87. Organization

Scout dog teams may be organized into squads or sections of—

- a. Infantry platoons (scout dog).
- b. Composite tactical dog platoons.
- c. Composite tactical dog companies.

88. Restatement of Mission

The scout dog team's mission is to support infantry and combat support type units in tactical operations against hostile forces by detecting and giving *silent*, early warning of any foreign presence outside the main body of the patrol or other group with which the team is working, i.e., to reconnoiter for and report enemy presence. Specific tasks dog teams are capable of performing include:

- a. Pinpointing friendly occupied positions through or near which a patrol departs or re-enters friendly areas.
- b. Assisting a patrol infiltrating an enemy area by locating outpost positions.
- c. Providing, during movement, early detection of friendly or enemy forces, natives, or inhabited areas the patrol desires to avoid.
- d. Detecting ambush sites, close-in snipers, mines, boobytraps, and similar dangers, including tripwires.
- e. Providing, by placement at the rear, detection of forces seeking to follow the patrol.
- f. Providing early warning of enemy (or unidentified personnel) approaching patrol ambush sites, base perimeters, outposts and listening posts.
- g. Assisting in *cordon* operations.
- h. Pinpointing objectives.
- i. Locating or determining the extent of enemy positions or installations; e.g., camps, bases, bivouac areas.

j. Assisting in searching objectives and objective areas, camps, and villages for concealed individuals or groups, and caches of weapons, ammunition, equipment, or food (including detection of concealed tunnel or cave entrances, and holes dug in caves or riverbanks).

k. When a patrol is moving by boat, the scout dog team screens to the front, around bends in streams, and to the flanks and rear, performing in effect, any task the team can perform on land.

89. Capabilities and Limitations

a. A scout dog team's detection and warning capabilities are the combined results of—

(1) The dog's superior faculties:

- (a) Smell—40 times greater than human perception (estimated).
- (b) Sound—20 times greater than human perception (estimated).
- (c) Sight (moving objects)—10 times greater than human perception (estimated).

(2) The handler's skill in working and "reading" his dog.

b. A well-trained, physically fit, properly employed scout dog team *usually* can detect current or recent foreign presence outside the main body of a patrol before other patrol members; e.g., detect the *current* human presence of an ambush ahead of a patrol before any actions of the ambush reveal it to the patrol members; through detection of *recent* human presence warn of boobytraps dangerous to a patrol well ahead of detection by patrol members.

c. Besides human presence; a scout dog team can usually detect:

(1) Caches—A scout dog regards the scents of food, weapons, or equipment as foreign and alerts on any of these scents.

(2) Tripwires—A scout dog alerts on seeing or hearing a tripwire (even though the human scent of the installer has dissipated, the vibrations of a wire often produce sounds that are audible to a dog).

(3) Mine, boobytraps—A scout dog may recognize the distinctive scents of the explosives or other components of the devices (e.g., in the case of mines, freshly turned earth) and alerts on these scents, even in the absence of human scent.

d. A scout dog team realizes its fullest potential when wind conditions permit the dog to work on airborne scent.

e. A scout dog's detection capabilities are reduced when there is little or no wind, when the wind is from the flanks or rear, in areas of much noise or movement, and by unfavorable weather or terrain conditions; e.g., rain, smoke, fog, dust, dense undergrowth, heavy woods, or jungle. Under unfavorable wind conditions the scout dog is still effective in detecting by sound and sight.

f. A scout dog requires water more frequently and in greater amounts than a man.

g. Except for water requirements, a scout dog's need for rest and food, and its reactions to climate extremes, compare to those of a man; i.e., its effectiveness declines as it becomes fatigued, hungry, thirsty, overheated, or very cold.

h. Fatigue suffered by the dog, and physical fatigue and mental stress bearing on the handler, limit maximum effective performance by a scout dog team. (Reserve scout dog support, to permit periodic rotation of working teams, is desirable for patrols where the requirements for continuous support exceeds the expected performance limits.)

i. Proper use of a scout dog team may reduce the speed at which a patrol could otherwise move. For example, unless a patrol is moving directly into the wind, with favorable weather and terrain conditions, a scout dog team, to work effectively, usually must move left and right of the patrol's line of march, with forward speed reduced in proportion to the amount of left and right movement required.

j. Occasionally a scout dog simply is a slow worker, even in favorable circumstances, and may unduly reduce a patrol's speed of movement.

k. All alerts *must* be interpreted by the handler and any of them may require checking by the patrol (an action that may be very time consuming) because a scout dog cannot normally distinguish between friend, enemy, and neutral, and therefore alerts on any current or recent human scent it detects. For example, a dog reacts to an enemy squad lying in ambush ahead of a

patrol in the same manner as it would to a non-combatant civilian hiding nearby.

l. The necessity for a handler to concentrate his attention on his dog's actions prevents him from protecting himself and his dog. When preceding a patrol (the team's usual position), a dog team is highly vulnerable to enemy fire. Therefore, at least one patrol member must be assigned to protect each working scout dog team during operations.

90. Planning and Preparation for Use of Scout Dog Teams

a. When an infantry tactical dog unit is attached to a tactical unit, normally brigade size or larger, the unit commander advises and makes recommendations to the commander of that unit concerning the employment of his scout dog teams. When scout dog teams are employed with units that have not previously used them, personnel of these units will be briefed on the team's capabilities and limitations. This is absolutely necessary to the team's success in combat since unit commanders may not be familiar with the proper methods of employing scout dogs.

b. Prior to assignment to any operation the infantry tactical dog unit commander or his representative is carefully briefed on planned missions as far in advance as possible. This allows him to select teams that have worked with the supported unit before and/or those teams which will be most effective for a particular mission. It also allows the handlers time to prepare themselves and their dogs; for example, checking the dogs out for any physical handicaps that might limit their effectiveness on the operation, exercising their dogs to relieve excess energy from being kenneled, and running their dogs on short training patrols to stimulate their interest and to verify their proficiency.

c. The supported commander should especially seek to obtain scout dog support for his patrols when—

(1) Darkness severely restricts vision and otherwise limits human detection abilities.

(2) Weather or terrain conditions restrict visibility during daylight.

d. On reaching the decision that scout dog support is both desirable and practicable, the supported commander will—

(1) Determine the number of teams needed, including reserve support if periodic rotation is required.

(2) Seek to obtain a team(s) that has previously worked with his unit and arrange for the team(s) to join the patrol in time to hear the warning order.

(3) Obtain the handler's recommendations for the most effective employment of the team; for example, best working position, and selection of a route which, consistent with other factors, allows the team to operate most effectively.

(4) Include his detailed plan for the team's employment in the patrol order.

(5) Insure that supported personnel know that scout dog support is a *supplement* to patrol security and an *aid* when searching for concealed personnel or equipment, *not* a substitute for the patrol's own security measures.

(6) Insure that supported personnel know and, in their association with scout dog teams, strictly observe these precautions:

(a) They must not—

1. Feed a scout dog. Feeding by the handler *only* is a part of a dog's training.

2. Play with or pet a scout dog, except for familiarization—and then only under the handler's direct supervision. A handler's petting of and playing with his dog is also a part of the dog's training.

3. Make any move or gesture which a scout dog may interpret as a threat to its handler. Although not specifically trained to defend their handlers, most scout dogs develop a protective attitude toward them.

(b) When taking cover, patrol members must never jump on top of or too near a scout dog or its handler because the dog may react defensively.

(7) Integrate the team fully into the tactical unit to include participation in inspections and rehearsals in order to—

(a) Thoroughly familiarize the handler with the entire plan of operation.

(b) Help familiarize the dog with the scents of individual patrol members and with the sounds and motions of the patrol.

(c) Help familiarize unit members with the team's methods of operation.

(d) Insure that the team is properly prepared; for example, the handler camouflages himself and his equipment and tapes or wraps metal parts of the dogs working harness to eliminate unnecessary noise.

(e) Insure proper support for the team; for example, designation, if required, of unit members to carry extra water and/or food for the dog and assignment of one or more patrol members to provide the team security while it is working.

e. Before an operation the scout dog handler will—

(1) Brief the tactical unit on the team's capabilities and limitations, the temperament of the dog, and any items of special interest pertaining to the team.

(2) Explain and demonstrate the team's various methods of operation (as pertinent to the tasks to be performed).

(3) Scent-familiarize the dog with *each* unit member.

(4) Allow men who have not previously worked with scout dogs, particularly those who are apprehensive, to touch and stroke the dog to show them they need not fear it.

Section II. TYPES OF EMPLOYMENT

91. Employment of Scout Dog Teams During Movement

a. Generally, the best position for the scout dog team is directly in front of the patrol. The team precedes the patrol or screening element, keeping on the assigned direction of movement. Wind conditions may dictate that the team move on the windward side of the route of advance to take maximum advantage of the dog's senses of smell and hearing.

b. It may become necessary at times to place the team in the rear of the patrol if the wind is blowing from the rear, or when speed is necessary (as in the approach march), since it is best to conserve the dog's energy whenever possible;

this is particularly applicable whenever scout dogs are employed as part of a screening force for a larger body of troops moving to an assembly area.

c. On a *reconnaissance* or *combat* patrol, where infiltration of hostile lines is desired, the scout dog can be extremely useful in alerting friendly forces to locations of enemy outposts. In these instances the team, when alerting on one outpost, can move to its right or left to find the location of the other, thus enabling the patrol to slip between them.

d. On all patrol actions one member of the patrol should be assigned the mission of protecting the handler and dog.

e. The distance at which the dog may alert depends on the weather and terrain. It may be 300 meters or it may be 30 meters. Once the dog alerts, the handler should signal the patrol to halt (usually by getting down), and he waits for the patrol leader to move up (on the side opposite the dog) to receive information of the enemy. If contact is to be made, the handler, instead of moving at the patrol's rear, should simply remain in place to allow the patrol to pass through his position then he falls in at the rear. This procedure eliminates unnecessary movement and risk to the scout dog team. In the event that a firefight develops, and the team is at the point position, it should remain in place. When possible it should move to the center of the patrol or to a position which would least interfere with the patrol's fire.

f. The most ideal conditions for working a scout dog are found in those areas sparsely inhabited with few distractions. It must be remembered that a scout dog is unable to distinguish between friend or foe and may alert on friendly personnel in the field. Therefore, it is vital that the handler and patrol leader know when and where other friendly units may be employed at any particular time.

92. Employment of Scout Dog Teams on Outpost and Ambush Patrols

a. When employed in support of an *outpost* or *listening post*, scout dogs should be placed far enough in advance of these posts to reduce distractions to the dog. However, the team(s) should be close enough so that friendly contact can be maintained at all times and the team's position is not placed in jeopardy in case of an enemy attack or infiltration.

b. If, while manning an outpost, the dog gives silent warning of hostile presence, the team should immediately withdraw to the rear of the post so that it does not mask the fire of friendly forces. The handler should always have a prearranged route of withdrawal before going on outpost.

c. There are several methods by which a scout dog handler can alert the outpost commander of enemy approach. The handler will normally employ the method prescribed by the supported unit SOP. One simple, often used, method involves running a strong length of string between two points. Individuals on either end may alert the other by having a prearranged signal of one, two, or three jerks to indicate "be on the alert" or "enemy in sight."

d. The procedures for withdrawal and stationing of scout dog teams on an ambush patrol are the same as for outposts, except where the sector is too wide for one team to screen effectively then two or more teams may be employed.

93. Employment of Scout Dog Teams With Mechanized Units

Pending the final development of electronic remote control equipment and doctrine for its employment, employment of scout dog teams with mechanized infantry will be restricted to several areas. Obviously, dismounted scout dog teams couldn't keep up with tracked vehicles during rapid movement or in many offensive situations. Although there have been cases where scout dogs have alerted from atop moving tracked vehicles, the wind caused by movement and the engine noises and odors will usually make alerting impossible.

94. The Offense

If scout dog teams are employed with mechanized infantry in offensive operations, they will normally ride in or on the vehicles, and may be effectively employed in one or more of the following roles:

a. The scout dog team and its security element may dismount to check suspicious areas or obstacles, especially where reconnaissance by fire or aerial observation is undesirable or not feasible.

b. Scout dog teams may work dismounted for short periods where natural or man-made obstacles, weather, or terrain restrict forward speed to a minimum.

c. When confronted by a river or stream, and the tactical situation permits, the dog can be directed to the far side to check for enemy positions, mines, or boobytraps.

95. The Defense

Scout dog teams can be effectively employed with mechanized infantry in the defense much as they are employed with dismounted infantry. Here, their capabilities can augment those of night vision devices and sensors, especially since the dog's senses can provide a wider range of detection possibilities than any single counterintrusion device.

96. Employment of Scout Dog Teams With Airmobile Units

Experience has shown that scout dogs can effec-

tively be employed with airmobile infantry in most airmobile operations.

a. Transportation by Helicopter. Whether on an operation or when being transported by helicopter, there are a number of rules which the handler must follow:

(1) The scout dog must first be accustomed to riding in ground vehicles.

(2) Dogs must be muzzled prior to entering the aircraft.

(3) If more than one team is on an aircraft, they should be separated as much as possible.

(4) Dogs should sit between and/or behind the handler's legs (fig 50). During movement, the dogs should be encouraged to lie down.

(5) Dog teams should board the aircraft last and exit first.

(6) Although the dogs may have to be help-

ed aboard at first, most dogs are soon able to jump on and off by themselves. Although most dogs enjoy riding helicopters, some may become over-eager to exit the aircraft as it approaches the ground. Handlers must exercise caution to insure that their dogs don't jump off until it is safe to do so.

b. Employment. In addition to normal employment on the ground, there are a number of specific means of employing scout dogs on airmobile operations:

(1) A scout dog can be rappelled to the ground to check a landing zone for enemy personnel, mines, or boobytraps.

(2) Scout dogs can quickly check a landing zone as the supported personnel are dismounting and deploying.

(3) Scout dogs can check a potential pickup zone for enemy personnel, mines, or boobytraps.



Figure 50. Scout dog team in HU1D.

97. Employment of Scout Dog Teams on Waterborne Operations

a. Where the tactical situation requires the infantry to conduct waterborne operations along rivers, streams, and canals of flooded marshlands, scout dog teams can be effectively employed. Under these circumstances a patrol is extremely vulnerable to ambush due to its precarious position on the water and the possibly reduced visibility caused by high banks or bordering vegetation. A trained scout dog team can reduce these dangers by screening to the front, around blind bends, and to the flanks or rear.

b. Employment.

(1) Ordinarily the scout dog team will be employed with the lead element of the patrol; the dog and handler taking up a stationary position in the bow or stern of the craft.

(2) Due to the irregular wind drifts (caused by the high banks and water currents) this screening element should follow a zigzag course down the canal or stream, working from one bank to the other.

(3) If there is a prevailing wind blowing off either flank, however, the screening element should follow the bank farthest away from the upwind flank so that the dog won't get caught in any dead space caused by the scent being blown over the canal bank. The principles of wind utilization are no different than when running land problems.

(4) It should not be construed, however, that the dogs always work from the lead boat. At times the wind may be blowing from the rear and this will necessitate placing the dog in the stern of the last boat.

(5) In those instances where only one boat is employed, then the dog should be placed in the bow or stern, depending on the wind direction, and allowed to remain there.

(6) It is not advisable to change the team's position once the boat is afloat. Should the boat be too small or crowded there is always the risk of the craft being capsized. There is also the danger of the dog biting a member of the patrol, or making other undue noises which would alert the enemy. If it becomes imperative for the team to change positions, then the boat should be pulled onto land where the exchange can be made with the least possible delay, noise, and/or confusion. This can be done by off-loading the team and then reloading them after other patrol members have shifted positions. The most important point to remember is not to risk any change of

position where the possibility exists of capsizing the boat. This can cost lives, equipment, and the success of the mission.

c. Actions of Handler on Alert.

(1) The handler should be able to recognize by the dog's actions the type of alert (scent, sound, or sight), the general direction of the alert, the approximate distance of the enemy, and the general size of the hostile force.

(2) Following the dog alerting, the handler should notify the patrol leader (who should be in the same boat as the team) by the most expeditious and silent means available. Ordinarily this can be done by arm-and-hand signals due to their close proximity to one another.

(3) If the patrol leader directs that contact be made with the enemy, or that the alert be investigated, the boat should be beached and all members required to disembark. Then the team should take whatever action is dictated by the situation; e.g., follow up the alert, or if contact is imminent, remain back at the shore with a bodyguard, but not in the boat. This position is too vulnerable, and in case the enemy slips into the landing area the team has a better chance of survival on land.

d. Techniques of Loading and Off-Loading.

(1) Prior to entry into waterborne training exercises, all dogs must be thoroughly obedient and under absolute control of the handler.

(2) Practice should start with dogs being accustomed to getting in and out of a boat tied to a pier or bank. This should be repeated as often as necessary until the dog shows no fright and can manipulate any required maneuver without threat of capsizing the craft. To accomplish this maneuver the handler should always enter the boat first. Then he can either lift the dog into the boat or have it enter by itself. The choice depends on the physical relationship of the boat to the bank or pier. The reason for the handler entering the boat first is so that he can be there to control the dog, and give encouragement if necessary.

(3) The team should also be the first to enter the boat. While they are doing so other members of the patrol should be steadying the craft to prevent it from capsizing.

(4) The team should also enter the boat from the center portion, unless the bow or stern can be stabilized. After entering the team should immediately take up positions in the stern or bow of the boat (fig 51).

(5) Once aboard the boat the dog must remain silent. It may be permitted to lie down only if the situation or patrol duration allows; otherwise, the dog should be kept in the sitting position, facing forward or to the rear of the craft depending on where it is stationed to take best advantage of the wind.

(6) The changeover is made before entry into the boat. The boat may be too crowded or too easily capsized to permit making the changeover once adrift.

(7) To off-load a scout dog the procedure is reversed, as explained previously (fig 52). It is important to note that during off-loading exercises the dog is not permitted to jump into the water, unless absolutely necessary to gain the shore, because the resulting noise of splashing and shaking itself to dry off will alert any enemy in the immediate vicinity of the landing.

(8) The scout dog team and patrol members of the lead boat should go ashore to reconnoiter the riverbank at suspected danger points (fig 53).

(9) When effecting any waterborne operation it is imperative that the dog be silent and under complete control of the handler at all times. This important point is repeated because any noise could cost the lives of the patrol.

98. Employment of Scout Dog Team in Northern Operations

With proper training and acclimatization, scout dog teams can be employed in mountainous, arctic,

or subarctic regions. The German Shepherd's dual coat enables it to adapt to almost any climate.

a. Weather is an important factor to be considered in the estimate of the situation and may dictate a course of action. As an example, the attacker in a snowstorm with the wind at his back is at a marked disadvantage, as the scent will be detected by the dog long before the attacker comes into view.

b. Snow enhances the movement of troops suitably equipped and trained, but reduces the mobility of troops lacking proper equipment and training.

c. Best employment in deep snow is by the use of a long leash, or off leash provided that the dog is under control.

d. The hard crust formed on snow will sustain the weight of most dogs. Daily inspection of the dog's pads is necessary as hard, crusted snow and ice will wear down the pads and may cause an ineffective team. Dog boots may be used in this environment (fig 54).

e. Snow, rain, sleet, and fog have a tendency to reduce the strength of a scent; however, it is not always the dog but sometimes the handler that is affected most by the elements. The distance at which dogs can pick up human scent varies with conditions.

f. Scout dog teams may be assigned to work with mountain and/or ski troops operating 10,000 to 12,000 feet above sea level. However, in order to function efficiently at such high altitudes the



Figure 51. Waterborne patrol with scout dog team.



Figure 52. Scout dog team unloading from assault boat.

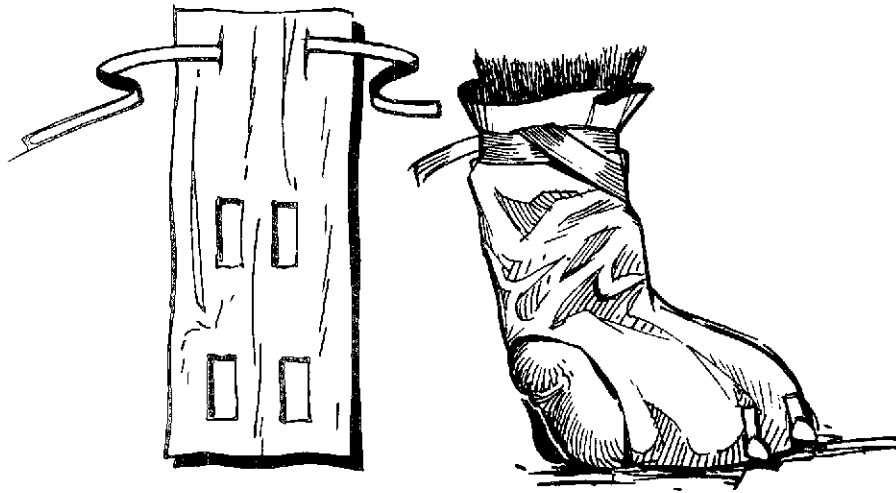

Figure 53. Scout dog team on reconnaissance patrol.

handler and dog must be trained to move over cliffs, rocks, ravines, glaciers, and deep snow.

g. The handler's knowledge must also include how to prepare shelters (FM 20-20).

h. Setting up bivouac areas will vary according to the terrain encountered on a particular operation. Living conditions are improved, however, if the area is used longer than one night (FM 31-71, and FM 21-50).



① DOG BOOT OPEN TYPE

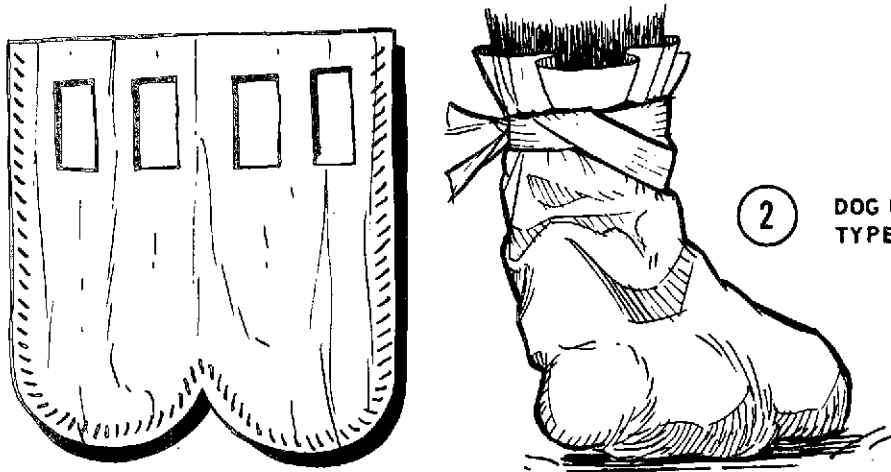

② DOG BOOT CLOSED TYPE (STITCHED)

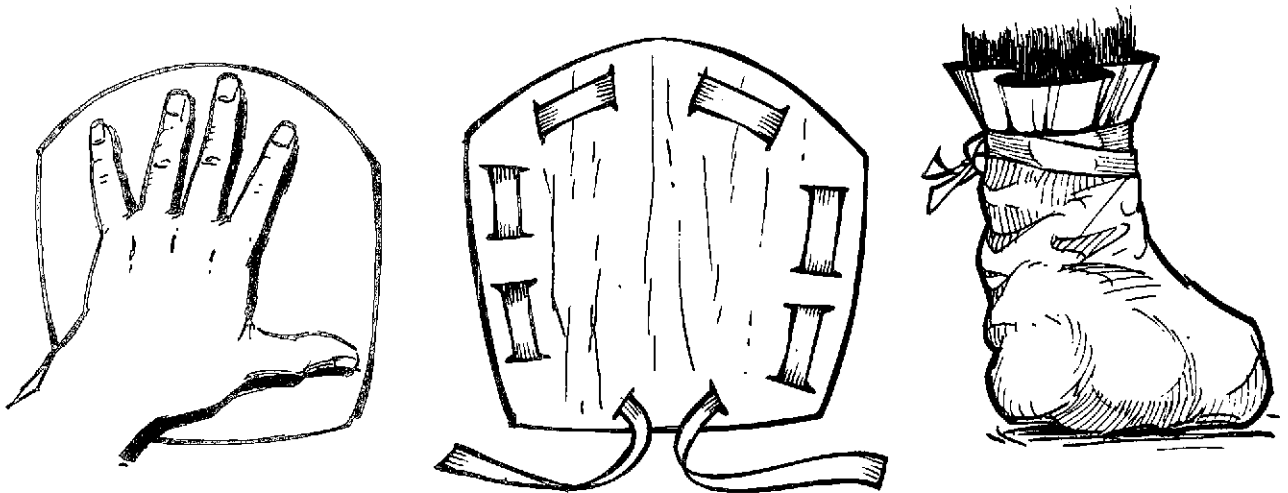

③ DOG BOOT CLOSED TYPE (LACED)

Figure 54. Dog boots.

99. Desert Operations

a. Most deserts around the Mediterranean Sea are arid regions with a high evaporation rate and a yearly rainfall of less than 10-inches. (In the Gobi Desert water can usually be found close to the surface.) Temperatures during the hottest part of the day are well over 100° F. and often range between 20° to 30° F. at night. Thus, it is best to work dogs during the cooler night temperatures.

b. Desert winds are variable and often unpredictable. In some parts of the Sahara Desert light northerly or westerly breezes occur during the day and are common after sunset. Winds are generally constant in the deserts of the Middle East where they blow continuously for a number of days at a time. (The Seistan Desert in Afghanistan and Iran is noted for its "wind of 120 days" which blows steadily from May until September.) Storms of hurricane velocity are frequent throughout the year, and they are often accompanied by rapid temperature changes. These storms blow sand so thick and forcibly that it can be dangerous to troops who are not trained to protect eyes and nostrils and otherwise cope with such conditions. Scout dogs must be similarly protected. Wind, sand, and dust are particularly irritating to mucous membranes and may cause local irritation of near-disabling nature. The wind, besides drying mucous membranes and chapping the lips and other exposed skin surfaces, carries dust and sand particles which penetrate clothing and goggles. *Irritative conjunctivitis*, caused by the infiltration of fine particles into the eyes, is a frequent complaint of soldiers even when they wear goggles. Obviously, these conditions can severely limit the performance of men and dogs.

100. Casualty Procedure

There are a number of specific procedures which must be followed should a handler or dog sustain injuries in combat.

a. A wounded or injured handler is treated according to the supported unit's casualty plan.

(1) If a handler is to be left for later evacuation, his dog will remain with him.

(2) If a handler is to be evacuated by the patrol a member of the patrol should be detailed to lead the dog on-leash to the pickup point. If this is not possible, the dog may be turned off leash, as most dogs will follow their handlers.

Caution: Under no conditions should a member of a supported unit attempt to work the dog.

b. Some dogs may become overly defensive and try to prevent anyone approaching their handler to administer first aid. In this situation every effort should be made to get the dog away from the handler so that he can be treated and evacuated. Several suggested methods are:

(1) Coaxing the dog away with friendly words or food.

(2) Throwing a poncho over the dog to immobilize it.

(3) Roping and tying the dog.

c. If none of the above works, or the tactical situation or nature of the handler's injuries does not permit the above, then the dog **MUST** be destroyed. **NO MATTER HOW VALUABLE OR COSTLY THE DOG, HUMAN LIFE ALWAYS TAKES PRECEDENCE.**

d. If a dog is wounded or killed, it is evacuated under the same conditions as a human casualty. The handler *always* accompanies his dog.

APPENDIX A

REFERENCES

AR 190-12	Military Police Working Dogs.
AR 700-81	Department of Defense Dog Program.
FM 8-35	Transportation of the Sick and Wounded.
FM 20-20	Basic Care and Training of Military Dogs.
FM 20-32	Landmine Warfare.
FM 21-50	Ranger Training and Ranger Operations.
FM 21-75	Combat Training of the Individual Soldier and Patrolling.
FM 31-22	US Army Counterinsurgency Forces.
FM 31-25	Desert Operations.
FM 31-35	Jungle Operations.
FM 31-70	Basic Cold Weather Manual.
FM 31-71	Northern Operations.
FM 31-72	Mountain Operations.
ATP 7-167	Infantry Platoon (Scout Dog) (TOE 7-167).
ASubjSched 7-39	Infantry Platoon (Scout Dog) (TOE 7-167).
ATT 7-167	Infantry Platoon (Scout Dog) (TOE 7-167).

APPENDIX B

PATROL BRIEFING DATA GUIDE

Section I. INTRODUCTION

1. Assemble all patrol members in order that they may see and hear all instructions and demonstrations.
2. Identify yourself and your dog (name and unit).
3. Coordinate with patrol leader on time and place for patrol orders, rehearsal, and other information.
4. Always try to rehearse with patrol prior to moving out on assignment.
5. Make sure dog smells every member of the patrol.

Section II. CAPABILITIES

6. Dog can give early warning (silent) of individual or group of people nearby in vicinity of patrol, i.e., silent early warning of ambush or sniper.
7. Dog can detect an infiltrator or a group of persons infiltrating the perimeter.
8. Dog can assist in the detection of tunnels and/or other devices used by the enemy as storage locations for food and supplies.
9. A dog's alertness and senses of smell, sight, and hearing are considerably better than those of a man.
10. A dog should be used on point whenever possible.
11. If vegetation is dense, a trail breaker should move ahead of the dog. The dog will still be able to use its senses of detection.

Section III. LIMITATIONS

12. A dog should only be worked by one qualified handler.
13. If speed is essential, the team should be moved to the rear.
14. A dog team does not join the attack unit or the enveloping unit.
15. Wind plays an important factor, when working the dog's ability to alert.
16. Alerts can vary according to the wind velocity, wind direction, the concentration of human scent, humidity, density or openness of the terrain and the amount of confusing noises in the area.
17. Never split a dog team.
18. If a dog is wounded it should be evacuated under the same conditions as a human casualty.

19. If a handler becomes a casualty and the dog becomes aggressive and the handler cannot be administered aid due to the dog, the dog *MUST* be destroyed.
20. Patrol members *MUST NOT* feel an exaggerated sense of security due to having a dog team in their patrol, nor must they become agitated and apprehensive because of the presence of the dog.
21. One man should be assigned to the dog team from the patrol unit as a body guard for security. This is due to the dog handler needing both hands to control the dog and cannot use his weapon effectively.
22. In hot weather, carry extra water for the dog as it dehydrates quickly.
23. If more than one dog is used on a patrol, the extra dog(s) should be kept in reserve and the point dog should be relieved frequently, especially in rough terrain.

Section IV. CAUTIONS TO PATROL PERSONNEL

24. Warn patrol members not to pet the dog. It may become noisy or aggressive.
25. Always approach handler on the right side.
26. When taking cover, avoid jumping too near the dog or the handler.
27. Checking danger areas: Ask patrol leader; mission depends on situation and terrain.
28. Village surveys: Check with patrol leader on assigned section.

APPENDIX C

SENTRY DOG TRAINING

Section I. BASIC TRAINING

1. Basic Training Required

The basic obedience training requirements for sentry dogs are identical to those outlined in FM 20-20.

2. Advanced Obedience

a. Advanced obedience training consists of requiring the dog to run an obstacle course and to perform all exercises off leash and without the use of command gestures. Since sentry dogs are normally used at night when gestures are useless, it is essential to train them to understand and obey oral commands. This advanced training allows the handler to acquire increased control over his dog and develops in the dog the discipline necessary for effective military service.

b. At the start of obedience training, the dogs are well separated to minimize the possibility of fights. A dog that attempts to attack another should be muzzled immediately as punishment. As the training progresses the handlers increase their control and the dogs become accustomed to working together in the area. The distance between dogs is then gradually reduced until handlers and dogs, working off leash, are capable of doing close order drill and obedience exercises at intervals of 4 feet or less.

3. Obstacle Course

Sentry dogs cannot be expected to maintain peak efficiency unless they are in top physical condition. This means, that in addition to receiving proper food and medical care, they must be exercised frequently, regularly, and strenuously. An obstacle course (FM 20-20) which may be constructed out of natural or salvage materials, provides an excellent medium for such exercises. All units which have sentry dogs assigned should have an obstacle course constructed. A good obstacle course should include but is not limited to

hurdles, ditches, low ramps for jumping, high ramps to teach the dog that it is safe to go wherever its handler takes it, tunnels to teach a dog to crawl, and walking logs or ladders raised above and parallel to the ground to teach a dog to be sure footed.

4. Mission

The mission of the sentry dog is to—

- a.* Detect and warn.
- b.* Pursue and attack.
- c.* Delay (assist in apprehension).

5. Use of Sentry Dogs

a. The sentry dog, as the name implies, is used principally on guard duty as a watchdog. This type dog is trained to give warning to its handler by growling, barking, or by silent alert. It is habitually worked on leash. The handler, keeping the dog on leash, walks his post and can depend on the dog to alert him of the approach or presence of strangers in or about the area being protected. When the dog alerts, the handler must be prepared to cope with the situation as circumstances dictate; that is, he must investigate (keeping carefully under cover), challenge and make an arrest if an intruder is present. The dog, being kept on leash and close to the handler, will attack on command of its handler.

b. The sentry dog can be used to advantage in such critical locations as—

- (1) Airplane dispersal areas (fig 55).
- (2) Gun emplacement areas.
- (3) Beach patrol areas.
- (4) Ammunition dumps.
- (5) Ration dumps.
- (6) Motor pools (fig 56).

- (7) Dynamite storage areas.
- (8) Guided missile sites.
- (9) Waterworks (fig 57).
- (10) Warehouses.

c. The sentry dog is a one-man dog. Each dog is assigned to only one handler for care, training, and duty.

d. Whenever practical, sentry dogs should work downwind from the area being protected to increase their alerting range.

e. There is no need to withdraw sentry dog teams from post during rainy weather. Although a heavy rain will tend to reduce a dog's effective alerting range, its ability to detect intruders will still exceed that of the handler. No difficulties should be encountered in the employment of sentry dogs in cold climates where temperatures fall to 40° F. below zero. The dogs will adjust rapidly to the extreme temperature; however, for peak efficiency in such cold climates, carry out the following special instructions.

(1) Assign the dogs to their duty sites during the summer months so they can gradually become acclimated before cold weather sets in.

(2) Cold weather housing for dogs should be unheated and located out-of-doors.

(3) In extremely cold climates, provide the dogs with boots to protect their pads against ice cuts. Dog boots may be made from canvas or leather (fig 54).

6. Selection for Training in Sentry Work

To be suitable for sentry training, dogs should possess the desirable traits in the following degrees:

- a. Intelligence—moderate to high.
- b. Willingness—moderate to high.
- c. Energy—moderate to high.
- d. Aggressiveness—high.
- e. Sensitivity—low to moderate.

7. Training Conditions

a. *Functions of the Handler.* In addition to teaching the dog to obey his commands, the handler must instill in the dog the idea that every human, except himself, is his natural enemy. He does this by encouraging the dog to alert at the presence of any stranger and always be suspicious. It must be emphasized that the handler NEVER PERMITS ANYONE TO PET OR MAKE FRIENDS WITH THE DOG HE IS TRAIN-



Figure 55. Guarding aircraft (sentry dog).

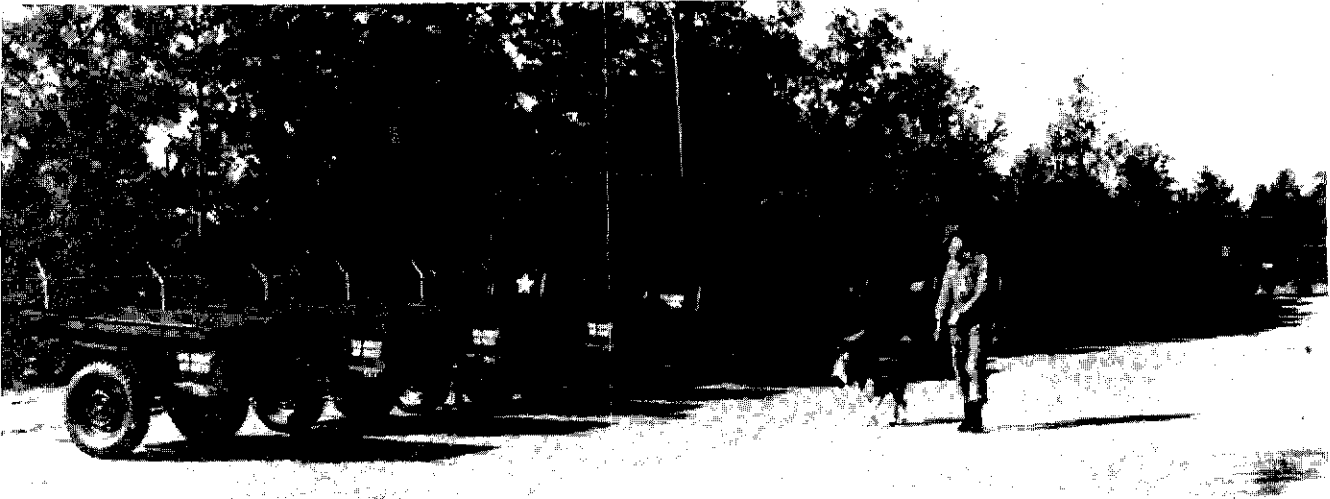

Figure 56. Guarding motor pool (sentry dog).



Figure 57. Guarding waterworks (sentry dog).

ING. He must remember that he is the only friend the dog must recognize; he is the ONLY master. For the same reason, the handler must never pet any dog except his own. He must always practice safety.

b. Functions of Assistant. An assistant is used to act as agitator and decoy. The agitator sharpens the dog's aggressiveness by agitating and angering the dog and builds up its self-confidence by retreating as soon as the dog makes

an aggressive move toward him. He approaches the dog in a threatening manner, but when the dog makes the slightest move toward him, he retreats. His manner of approaching the dog may be varied according to the dog's temperament. It is essential, however, that in every encounter between the dog and the agitator, the DOG MUST ALWAYS BE THE WINNER. The agitator is as important in sentry dog training as the handler, and his work should be carefully

supervised by the instructor. For variety, different men are used as agitators. The handler of one dog can act as agitator for the handler of another dog (fig 58).

c. Location. Training starts in the regular training area. As soon as the dog progresses, it is moved to different locations, chosen to resemble various types of sentry posts.

d. Time. Initial training is done during daytime. When the dog alerts consistently to the presence of unfamiliar persons in daytime, final training is undertaken at night.

8. Equipment for Sentry Training

The following equipment is required:

a. The handler will need a chain choke collar, a 5-foot leather leash, a 25-foot leash, a flat leather collar, a stake, and a kennel chain.

b. The agitator needs a small flexible stick, rolled up sacking, or other harmless weapon, and an attack sleeve (fig 59).

9. Training Procedure

Training to make the sentry dog aggressive is divided into three stages:

a. An Underaggressive Dog. This dog reacts negatively to the presence of the agitator. It may stand and wag its tail, throw itself on the ground, or try to run away from the agitator. In this case, the agitator approaches the dog from the flank and hits or seizes it from behind. The handler sets an example for the dog by making threatening gestures toward the agitator, who imitates a dog's growl. When the dog, in trying to protect itself, snaps or growls at the agitator, the agitator at once stops agitating the dog and quickly runs away. In training this type of dog, it is very important for the handler to exaggerate his praise and encouragement whenever the dog shows the slightest sign of aggressiveness, and for the agitator to exaggerate his simulated fear of the dog. This procedure must be repeated until the dog's confidence is built up and it tries to attack the agitator as

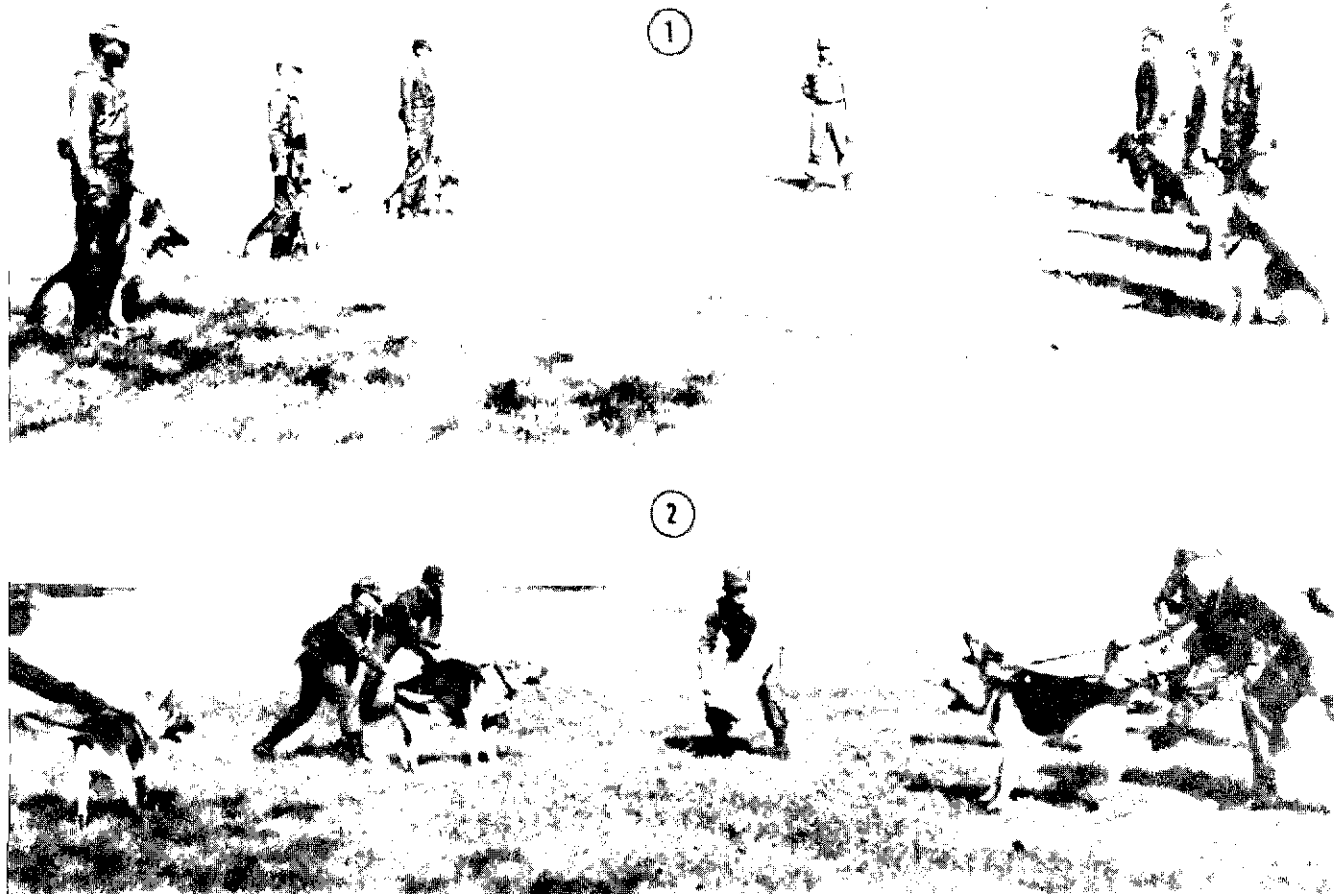

Figure 58. Preparation for agitation.

soon as he approaches. Training for the day is concluded with praise by the master as the agitator disappears.

b. A Moderately Aggressive Dog. This dog is the ideal dog to train for sentry work. It barks or growls as soon as the agitator appears, lunging on the chain and trying to attack. The agitator runs away and out of sight. As soon as the dog responds in this manner, the handler praises it lavishly and, if the dog is not too excited, pats it. When the handler is convinced that the dog is aroused only against the agitator and that it has no tendency to attack indiscriminately, it may be considered ready for work off the stake. The exercise for the day is concluded with the agitator running away and the handler praising the dog and unchaining it.

c. An Overaggressive Dog. This dog is apt to lose its head, try to bite everyone within reach, and keep on barking even after the agitator disappears. In this case, the handler scolds the dog. He shouts NO, jerking on the leash until the dog calms down. He must be careful not to step within reach until the dog stops barking and growling. When he is sure that the dog is calm enough, he approaches it, speaking soothingly, and praises and pets it. This procedure is repeated, except that the agitator appears and disappears immediately. As the dog shows signs of directing its aggressiveness toward the agitator, the handler lavishes praise and tries to indicate to the dog that its hostility must be directed only at the agitator. After two or three trials, stop train-

ing for the day. It is resumed the following day with the dog chained to the stake as before. It is chained to the stake for this exercise until the dog has demonstrated that it will not bite the handler, no matter how excited it becomes.

10. Agitation

a. Advanced agitation training consists of agitating the dog to the extent of making it bite at the agitator. The agitator wears the attack sleeve to give the dog something to actually bite. He uses a stick or burlap bag to agitate the dog. The agitator builds the dog up by acting frightened and backing away every time the dog advances. Without exception, the dog must always be the winner. A handler *never* agitates his own dog.

b. The dog always wears the leather collar for agitation training. As soon as a session has been completed the collar is removed (fig 60). In this way the dog soon comes to associate the leather collar with agitation and when it is placed around its neck the dog will begin to search for an agitator. The dog also wears the leather collar while performing sentry duty. It is important that this (leather) collar-agitator association be established early and firmly. The choke chain is used only when taking a dog to or from the kennel area and during obedience training. It is agitation which develops in a dog the aggressiveness and viciousness essential to an effective sentry dog. Its aggressiveness and viciousness determine its alertness on post and urge to attack. It is important to keep in mind that each



Figure 59. Line agitation.

dog is an individual with a distinct temperament of its own, and to obtain the best results agitation must be suited to the dog. There are three principal methods of agitation.

(1) *Line agitation.*

(a) Handlers and dogs form a single line at intervals of about 15 feet, the dogs standing at heel. The agitator quietly approaches one end of the line from the rear. He stops when he is about 30 feet from the first dog and handler and the instructor commands ABOUT, FACE. All handlers and dogs execute about face, and the first dog and handler advance slowly toward the agitator. The handler incites his dog with the command WATCH HIM. When the dog comes within 10 feet of him, the agitator acts excited and afraid and begins to retreat, walking backwards. The dog is allowed to approach within 3 feet of the agitator who then agitates the dog a few moments with his stick, while continuing to retreat. The handler then calls off his dog and leads him back of the agitation line to the other end while the next dog and handler start the same procedure. This should continue until each dog has gone through three repetitions with the agitator. The dogs are NOT allowed to take hold of the agitator during this exercise (fig 59).

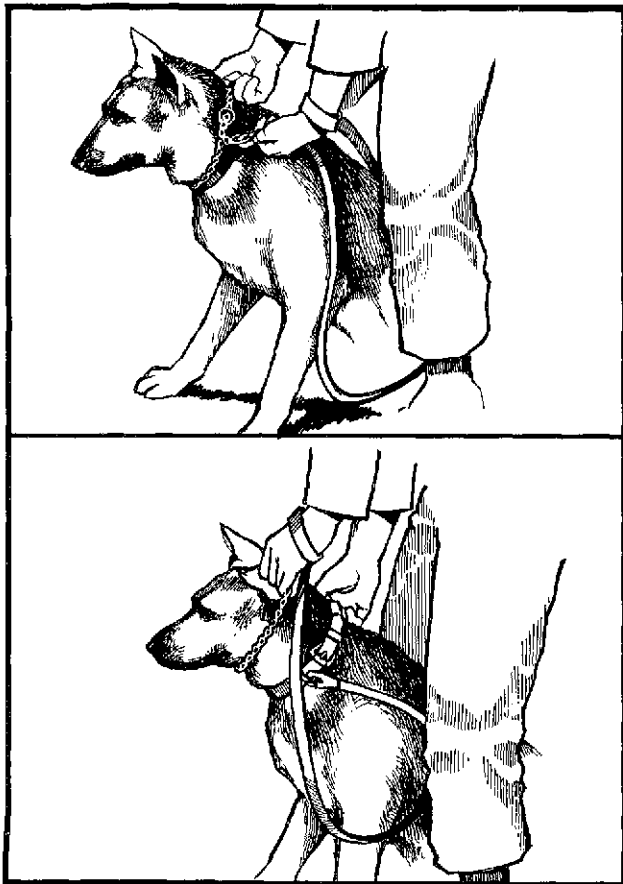

Figure 60. Changeover (sentry dog).

(b) Six naturally aggressive dogs are brought out at the same time. These are dogs which have demonstrated that they do not need to be chained to the stake. Between every two of these dogs is placed a dog that has reacted negatively to the first phase of training. All the dogs are lined up far enough apart so that they cannot get into a fight among themselves. Each dog is on leash at the left side of the handler. The command WATCH HIM is given when the agitator appears and walks toward the dogs. Some of the dogs will bark immediately; these should be praised by their handlers. The agitator concentrates his attention on the dogs that do not respond readily. He approaches them with his stick, threatens them, and jumps away. Inspired by the bolder dogs beside them, even the slow ones will eventually start barking. If properly encouraged by their handlers, they will understand that there is nothing to fear from the agitator, and that he will disappear as soon as they bark, growl, or make a move toward him. When all the dogs alert as soon as the agitator appears, he must vary his direction of approach and increase the distance at which he first appears. The dogs that detect him earliest are praised lavishly. It will be found that the slower dogs learn from their aggressive companions, as well as from their handlers. OVERAGGRESSIVE DOGS ARE NOT USED IN LINE AGITATION.

(c) When all dogs in the class alert at the approach of the agitator, a new man takes his place. The dogs learn in this way that *any* man approaching is an enemy. It is desirable to have numerous persons play the role of the agitator, and dressed in different clothing.

(d) The handler now plays the role of the sentry, walking post with his dog heeling on loose leash. (This simulated post must be changed each day so that the dog does not get accustomed to one, definite route.) When the dog and sentry have advanced a short distance, the agitator approaches from some place of concealment. If the dog has learned its first lesson, it will detect the approach of the agitator and will alert without help from the handler. If the dog does not alert, the handler gives it the cue by commanding WATCH HIM. As soon as the dog gives warning, the agitator runs out of sight and the handler praises and encourages the dog. If the dog does not respond correctly, the agitator conceals himself along the dog's path of advance, steps out quickly from his hiding place, hits at the dog with a stick, and jumps away. This will arouse the dog. Furthermore, the dog will learn that unless it gives alarm immediately upon de-

tecting the presence of a stranger, it will be corrected.

(e) When a dog detects and alerts to the presence of all strangers at a considerable distance without any help during the daytime, it is generally ready to be worked at night. It will usually be found that a dog is better at night because scenting conditions are more favorable and

its keen hearing is enhanced by the absence of distracting noises.

(2) *Stake agitation.*

(a) Stake agitation follows line agitation. The dog is chained to a tree, post, or stake in some open space away from the kennels. This exercise tends to further build the dog's confidence in itself in unfamiliar places. Some dogs are



①



②



Figure 61. Muzzle agitation.

naturally aggressive and do not need much agitation to become excited. To avoid accidents, training to arouse aggressiveness may be started by tying the dog to a stake with a kennel chain attached to the broad leather collar. It is advisable to loosen an inch or two of the earth around the stake so that the stake will give a little when the dog lunges, and not check it too sharply. The handler heels the dog to the end of the chain, orders it to sit and steps away from the dog. When the agitator approaches and comes within sight the handler puts the dog on the alert by the command WATCH HIM, uttered in a low voice, almost a whisper. The command WATCH HIM is used *only* during early training. It is a signal for the dog that it is on duty and must be prepared to detect any intrusion. The command should be eliminated as soon as the dog has learned that putting on the collar and leash signifies that it is on duty. WATCH HIM is never used in actual service to alert the dog. *The dog alerts the handler of danger, the handler does not alert the dog.*

(b) The agitator appears, equipped with a small, flexible stick or some other harmless weapon. He approaches the dog from an angle, not facing it directly. He looks at the dog out of the corner of his eyes; he does not stare at it. He strikes at the dog without hitting it and jumps

away. As the agitator strikes, the handler encourages the dog by commanding GET HIM, in a sharp voice. Dogs will respond to this procedure according to their natural aggressiveness.

(3) Muzzle agitation.

(a) This is an exercise for sentry dogs. The sentry dog is muzzled and allowed to attack its agitator who wears regular clothing. This actually is a test to determine if the dog will attack, on command, persons not dressed in the attack suit. During training many dogs seem to acquire an almost exclusive association between the attack suit and "enemy." This form of agitation will determine if a sentry dog is "Suit Happy" or not (fig 61).

(b) Dogs are never agitated from a vehicle. Eventually this will cause them to look for and react against vehicles instead of people. In addition, they become nervous and excited when vehicles approach, thus making it difficult to get them to enter one and ride calmly.

(c) Normally, dogs should be agitated at least three times weekly to keep them at the peak of their effectiveness, but the temperament of individual dogs should also be considered in determining the amount of agitation they need. Under no circumstances will a dog be agitated in the absence of its handler.

Section II. ADVANCED TRAINING

1.1. Quartering

The dog must learn to detect the presence of a human in partial or complete concealment either below, at, or above ground level. For this reason, the final stage of sentry training must include search in areas where decoys are concealed in such places as the branches of a tree, behind a fence, or in a ditch. It is desirable to work the dog on the 25-foot leash, as well as the short leash, so that it can enter buildings and other suspected places of concealment ahead of the handler.

a. Quartering is the method the handler and his dog use to search a section of terrain, taking full advantage of the wind, to locate any intruder that may be present. Scents borne by the wind may be elusive. Sometimes the dog can detect them from one spot whereas, from another spot just as close to the source of the scent, it may receive no scent at all. Therefore, to give the dog every opportunity to pick up a scent, the

handler must lead it systematically over a fair-sized area so that every breeze can pass through the dog's nose.

b. Figure 62 shows a quartering course lay out for training. The instructor lays out the course and selects the starting point downwind from the decoy. The handler and dog proceed through the course as diagrammed. The dog first alerts to a weak scent. The handler can then elect to further quarter the course or let the dog follow the weak scent directly to where the dog should give a strong alert. From this point, the handler lets the dog move in and find the decoy.

c. Figure 63 shows schematically how a handler and dog would work an area in the field to search out an intruder. Based on his knowledge of the dog, the handler knows that the alert at first is a weak one. The team continues to work, as shown, and the dog gives a strong alert and turns in the direction of the wind which is in the direction of the intruder.

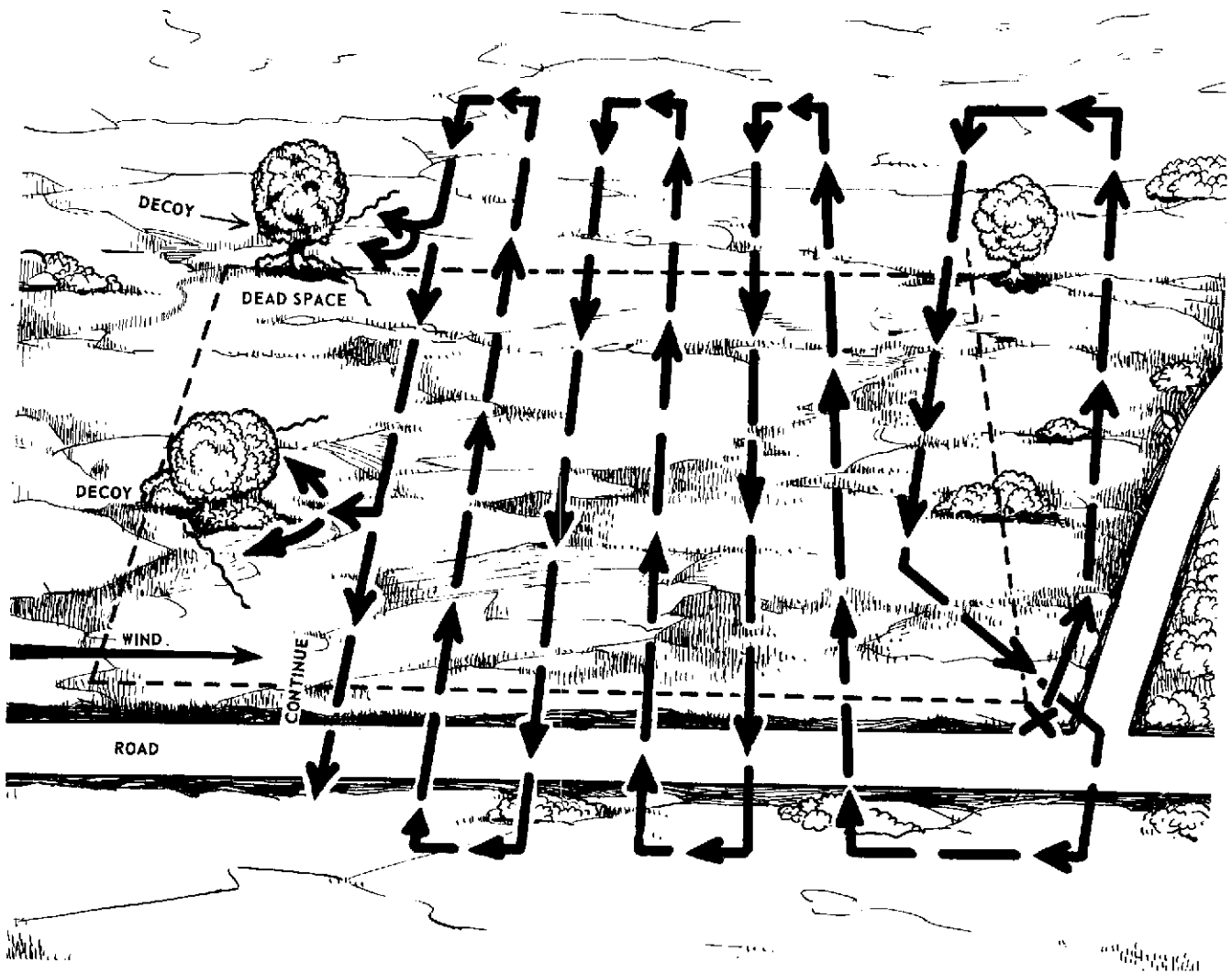

Figure 62. Quartering course.

12. Training Procedure

Before the dog and handler arrive in the training area, the instructor visually selects a route for the team to follow. The instructor prepositions human decoys at various intervals and at different distances away from and upwind to the prescribed route. The instructor and decoys must not walk the selected route as their odor will mark the trail.

a. The dog and handler then enter the training area, which is preferably one where high grass affords cover for the decoys. Once in the field, the handler has a collar on his dog and attaches the 5-foot leash. The dog wears the collar only when it is working. The handler removes it at the conclusion of the exercise. On starting the quartering exercise, the handler commands SEARCH, letting the dog precede him on a loose leash. The dog will then attempt to locate the

decoy by scent, sound, or sight. In this initial exercise, it is important for the decoy to be well-concealed from view and remain quiet, but within easy scenting distance and directly upwind from the dog.

b. The dog is encouraged to lift its nose and sample the wind well above ground level. When the dog detects a scent other than the handler's, it is likely to react in one of the following ways:

- (1) Tensing the whole body.
- (2) Raising his hackles (hair on neck).
- (3) Prick up ears.

(4) Giving other signs of alertness (easily recognizable by a keen observer), such as a desire to investigate, a slight inclination to whimper or growl, an active or distinctly rigid tail.

c. As soon as the dog gives evidence that it has picked up the scent, the handler praises it.

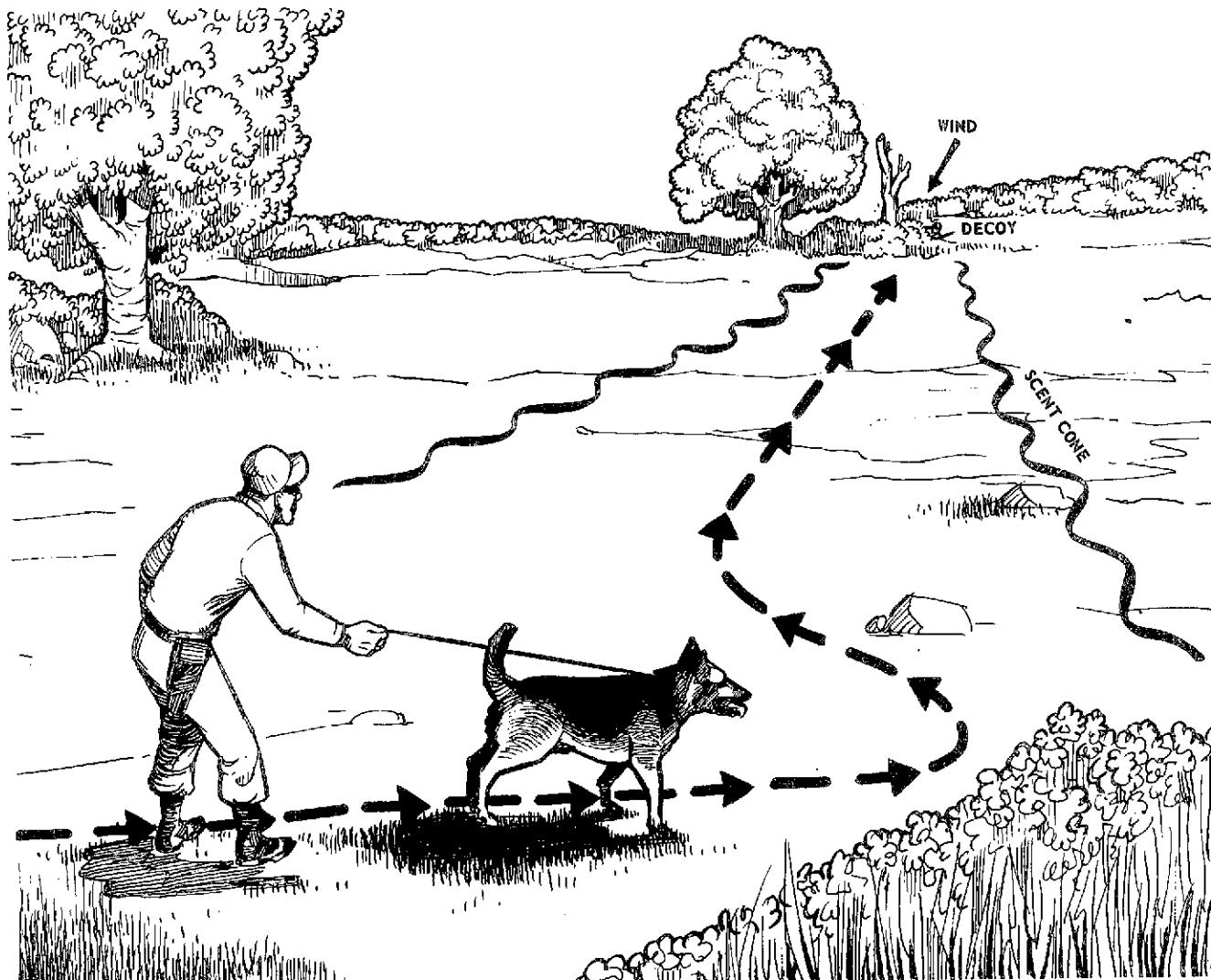

Figure 63. Quartering field.

Praise at this point must be given in a soft, almost whispering voice; it must not be insistent enough to divert the dog from its work. Some dogs when first going into the field will put their noses to the ground and attempt to pick up a ground scent. The handler must immediately discourage this tendency by placing his foot under the dog's chin to make it lift its head and then reprimand the dog saying NO in a stern voice. It is important that the dog's nose be raised to the proper scenting level IMMEDIATELY, if it attempts to ground trail.

d. When the dog gives an alert, the handler deduces the general direction to the decoy's hiding place and announces it to the instructor. If he is correct in his deduction, the instructor tells the handler to follow the scent. When the dog is about 10 feet from the decoy, the instructor tells the decoy to move out. The decoy exposes him-

self and runs rapidly to his right. The handler allows the dog to chase the decoy for 30 to 40 feet then turns off to his left to avoid contact with the decoy. The handler rewards the dog with praise and the exercise is considered concluded.

e. During repetitions of the exercise, the size of the quartering course is enlarged and the number of decoys is increased. The distances between the dog and the concealed decoys are lengthened progressively. The handler must give his dog every possible opportunity to locate the decoys. He stops at intervals so the dog can take advantage of every breeze, quartering the field if necessary for the dog to catch the scent. He pays strict attention to the dog's action and encourages it as soon as the dog shows signs that it may have scented a decoy. The dog is not always allowed to follow the scent to the decoy and give chase. The handler uses the chase as a form of

reward, but he should use it less frequently during training.

f. This exercise is repeated daily with the terrain and other conditions being varied. The decoy is concealed in underbrush, ditches, branches of a tree, behind rocks, or in any natural or artificial hiding place (fig 62).

g. The role of the decoy is played by a different man each day so that the dog will learn that it must pick up all human scent other than just that of its handler.

h. After the dog and its handler have established mutual understanding, they practice the exercise at night.

13. Attack Training

a. The dog is taught to attack and stop its attack on command. The command to attack is GET HIM and the command to release or stop attacking is OUT. At the command GET HIM, the handler drops the leash and the dog attacks.

On the command OUT, the dog releases and watches the intruder. The dog returns to the handler only on command.

b. The handler and his dog proceed to an area which is isolated from both pedestrian and vehicular traffic. In the training area, the handler puts the leather work collar on the dog and does not remove it until the exercise is completed. The agitator, dressed in an attack suit (fig 64), should be concealed upwind from the dog so that his scent will be driven directly into the dog's nose. For the first exercise in this phase of training, it is important for the agitator to be well-concealed, but within easy scenting distance and directly upwind from the dog. The handler commands SEARCH, and the dog then tries to locate the agitator by scent or sound. When the dog alerts and pulls on the leash, the handler should put his hand on the dog's flank, stroking it gently and whispering the words "Atta boy, Good boy," to praise the dog. He must praise the dog enough to encourage it, but must not distract the dog. The dog's attention must remain fo-

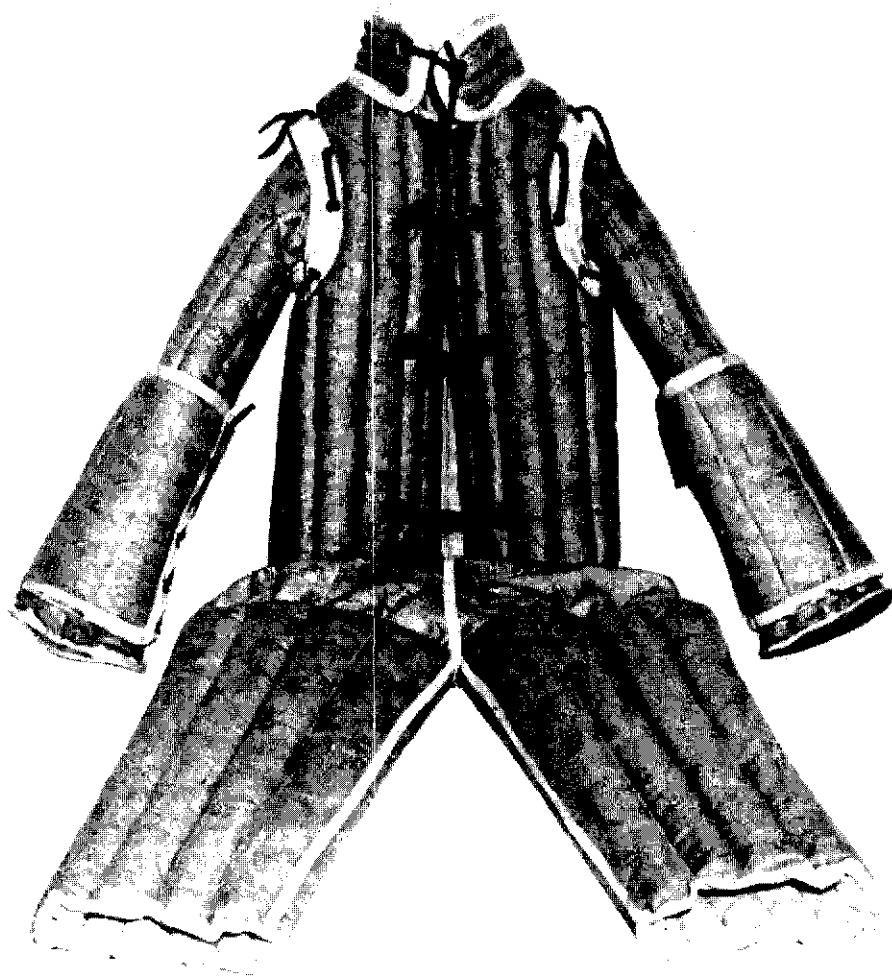

Figure 64. Attack suit.

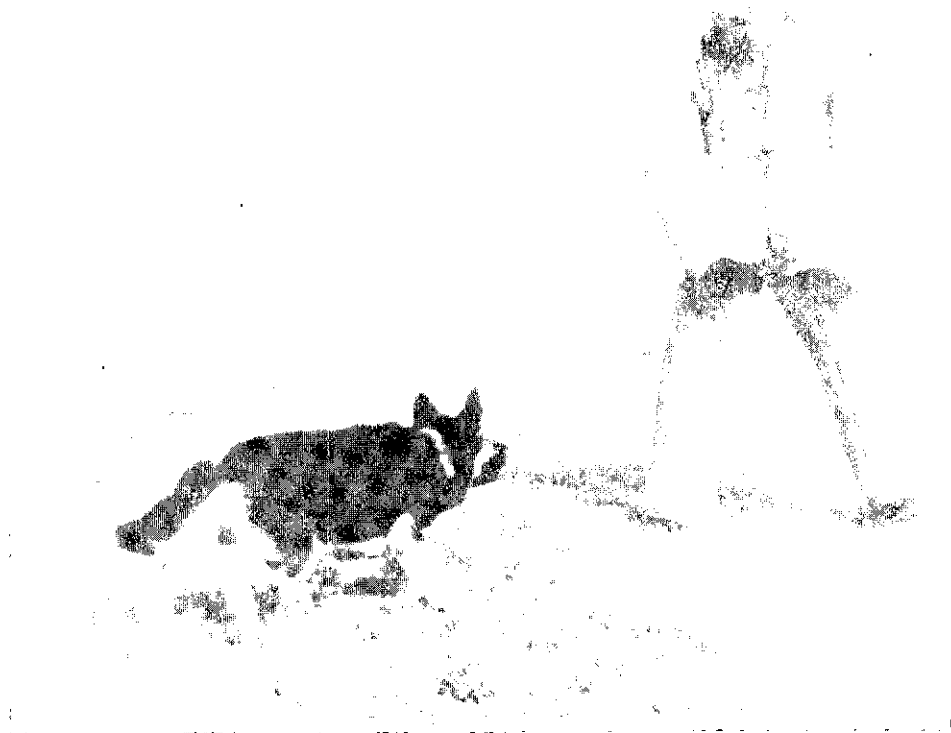

Figure 65. Dog attacking agitator (off leash).

cused in the direction of the agitator. The dog approaches the concealed agitator and the handler again uses words of praise and encouragement. When the dog is within a short distance of the agitator, the agitator breaks cover. The handler orders the agitator to halt and place his hands over his head. The agitator ignores the order and tries to escape. The handler then releases his dog and commands GET HIM. The dog then pursues and attacks the agitator (fig 65) who, after a brief struggle, ceases to resist. The handler approaches, commands OUT, and draws the dog away from the agitator, at the same time praising and patting the dog. He leads the dog about 10 feet away from the agitator and commands DOWN, STAY, and WATCH HIM. He then returns to the agitator and searches him, being careful never to place himself between the dog and the agitator. In the course of the search, the agitator strikes or pushes the handler to the ground and tries to run away. At this point the dog must attack the agitator WITHOUT COMMAND from the handler.

14. Attacking Under Gunfire

Attack under gunfire is taught after the sentry dog is well-trained and the handler is sure that

it will obey all commands or gestures to attack and cease attack. The agitator wears the attack suit. The procedure is like that prescribed in paragraph 13, except that when the dog flushes the agitator, the handler and the agitator exchange pistol shots, the handler firing first. The exercise then continues through all the stages of pursuit, capture, guard, and search. When exchanging shots, the handler and agitator should be careful not to fire close to the dog's head to avoid powder burns, particularly about its eyes and nose.

15. Guarding a Prisoner

On the command DOWN, the dog assumes this position in front of a motionless "prisoner" in the attack suit. The dog must not be close enough for the prisoner to injure it with a sudden kick. The handler then commands WATCH HIM to put the dog on the alert, and walks away to a hiding place where he can observe the dog's actions. The prisoner then starts to turn around, or walk or run away. If the dog does not attack when the prisoner moves, the handler immediately comes out of his hiding place and commands GET HIM. This exercise is repeated until the dog pursues and attacks the prisoner

whenever he moves. The exercise should always conclude with the handler returning to the scene, taking charge of the prisoner, and praising the dog.

16. Escorting a Prisoner

The dog is taught that a prisoner is not to be attacked when accompanied by the dog's handler, and walking slowly in front and slightly to the left of the dog. *Training example:* The prisoner suddenly turns in a threatening manner or starts to run away. The handler drops the leash and the dog, if well trained, will attack. At first, the handler may need to command GET HIM. The procedure is repeated until the dog attacks without command when the prisoner makes any sudden break, but refrains from attacking when the prisoner is marching in an orderly manner ahead of the handler. The handler praises his dog at the conclusion of each exercise.

17. Additional Training Notes

a. Importance of Loose Heeling. In walking a post, loose heeling is essential as long as the dog does not pull or tug on the leash. If a handler insists on close heeling, the dog is more likely

to concentrate on perfection in heeling; this means that its attention will be on the handler and not concentrated on the surrounding. Thus, the dog is likely to forget its main duty, which is to be on the alert at all times and ready to give alarm at the slightest provocation.

b. Importance of Distrust of Strangers. The sentry dog is taught not to make friends with strangers. *Training example:* The handler walks his dog on leash at the heel position. A stranger approaches uttering soothing words and coaxes the dog to come to him. As soon as the dog starts to respond with friendliness, the stranger slaps it smartly on the nose and jumps away. The handler then encourages the dog to attack the stranger. This is repeated with different people acting as strangers until the dog growls and barks on the approach of all strangers, no matter how friendly their attitude or how much they attempt to appease the dog. Next, a stranger tries to entice the dog with a piece of meat or any other bit of food the dog likes. If the dog tries to take the food, the stranger slaps it on the nose and runs away without giving it the food. Thus the dog learns that its handler is the only person to be trusted..

APPENDIX D

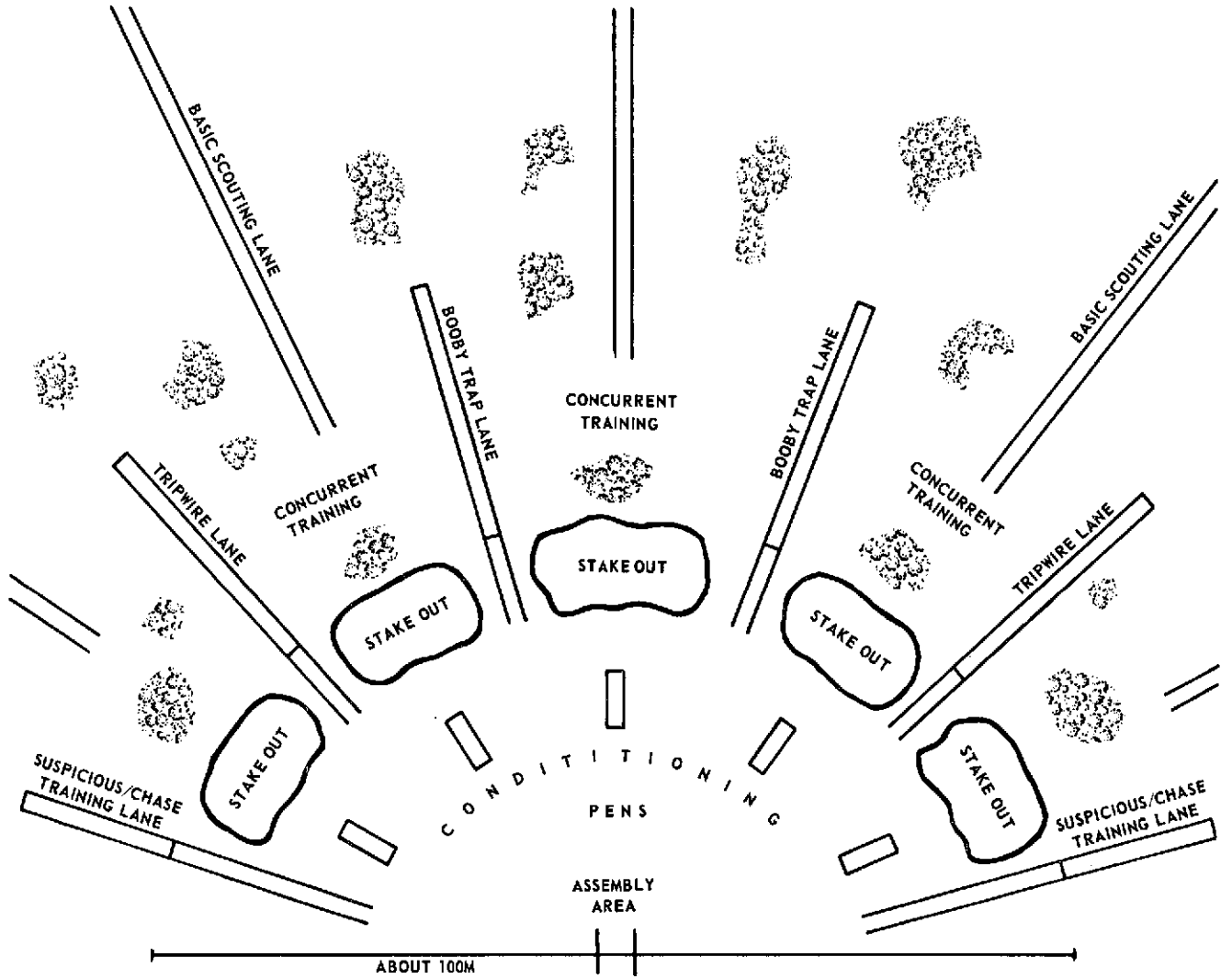

Figure 66. Example layout of basic scouting area (training).

INDEX

	Paragraphs	Page		Paragraphs	Page
Advanced scouting	82—86	69	Mines	48, 53	35, 39
Airmobile operations	96	74	Mission, team	4	3
Alerts, types of	37, 47, 58	29, 33, 43	Night training	67—69	53
Basic scouting	33	27	Noise discipline	35	27
Boobytraps	48, 54	35, 39	Northern operations	98	77
Caches	55	39	Offense	94	74
Capabilities, team	5	3	Praise-punishment method	20	9
Casualty procedure	100	80	Principles of dog training	13	6
Changeover	34	27	Range estimation	60	43
Chase	40	30	Rappelling	74, 75	57
Clock system	59	43	Requirements, dog training	15—19	6
Commands	39	29	Reward/food method	20	9
Conditioning steps	26	11	River crossing	72	55
Concurrent training	32	22	Scout dog team:		
Decoy	38, 44	29, 32	Capabilities	5	3
Defense	95	74	Evolution of concept	7	8
Desert operations	99	80	Limitations	6	3
Dividing pen	figs. 5, 6	13	Mission	4	3
Dog selection	9, 10	5	Responsibilities	8	4
Employment:			Team	3	3
Capabilities	89	71	Search, built-up areas, villages	76—81	66
Casualty procedure	100	80	Search chain:		
Limitations	89	71	Basic chain	29	14
Mission	88	71	Goal food	31	14
Organization	87	71	Pairing	30	14
Types of:			Procedure (10 steps):		
Ambush sites	92	74	1—Feed pan orientation	31	14
Desert operations	99	80	2—Recall training	31	14
During defense	95	74	3—Stay at heel	31	14
During movement	91	73	4—Moveout command	31	14
During offense	94	74	5—Reorientation on pan	31	14
Northern operations	98	77	6—Sit at pan	31	14
Outpost sites	92	74	7—Reorientation after sit	31	14
With airmobile units	96	74	8—Reconditioning of		
With mechanized units	93	74	“good”	31	14
With waterborne			9—Eliminating dropper	31	14
operations	97	76	10—Distance training	31	14
Use of teams	90	72	Timeout	31	14
Equipment	18	7	Searching:		
Evolution of concept	7	3	Above ground	64	51
Food:			Underground	63	50
Preparation	22	9	Underwater, riverbanks	65	51
Types of	21	9	Shaping procedure (6 steps)	27	11
Food-reward method	20	9	Silence	43	31
Goal food	31	14	Specialized training	70—81	55
Good—reinforcer word	25	10	Speed	42	31
Intermediate training	57—60	43	Team:		
Instructor/trainer	15	6	Capabilities	5	3
Limitations, team	6	3	Limitations	6	3
Mechanized operations	93	74	Mission	4	3

	Paragraphs	Page		Paragraphs	Page
Terrain:			Integrated support	85	69
Effects of	62	45	Intermediate:		
Training	19	7	Alerts, calling	58	43
Timeout	31	14	Clock system	59	43
Trainer/instructor	15	6	Range estimation	60	43
Training, dog:			Scope	57	43
General	11, 12	5	Night	67—69	53
Principles of	13	6	Preemployment	83	69
Requirements:			Pens	24	10
Dogs	17	7	Responsibilities	8	4
Equipment	18	7	Specialized:		
Handlers	16	7	Rappelling	74, 75	57, 58
Instructor/trainer	15	6	River crossing	72	55
Terrain	19	7	Search, built-up areas,		
Training, types of:			villages	76—81	66
Concurrent	32	22	Swampy, areas	73	56
Considerations:			Suspicious	36	29
Alerts, sound/smell	47	33	Tripwire(s) training:		
Breaking dog of tracking ..	45	32	Device, training	51	36
Chase	40	30	Introduction to	49	36
Decoys	44	32	Lanes	50	36
Handler actions relative			Method of (10 steps)	52	37
decoy	46	33	Types of	48	35
Silence	43	31	Veterinary supervision	23	10
Speed	42	31	Waterbone operations	97	76
Wind	41	30	Wind	41, 61	30, 44

By Order of the Secretary of the Army:

CREIGHTON W. ABRAMS
General, United States Army
Chief of Staff

Official:

VERNE L. BOWERS
Major General, United States Army
The Adjutant General

Distribution:

To be distributed in accordance with DA Form 12-11 requirements for Military Dog Training and Employment.